

Power Factor Controller
BR6000



CONTENTS

Section 1	General	3
Section 2	Installation of the controller / connection diagram	5
	2.1 Current measurement	
	2.2 Programming of phase-correction in special systems	
	2.3 Alarm output / fault messages	
Section 3	Operating modes and programming	7
	3.1 Automatic operation / display functions	
	3.2 Programming	
	3.3 Programming lock	
Section 4	Manual operation / Programming of fixed stages	13
Section 5	Service menu, Test run	14
Section 6	Expert mode	15
Section 7	Initial operation	16
Section 8	Control principle	16
Section 9	Interface	17
Section 10	Maintenance and warranty	17
Section 11	Troubleshooting	18
Section 12	Technical data	19
Annex:	Annex 1 Table of control series	20
	Description of control-series editor	
	Annex 2 Default settings	21
	Annex 3 Controller coupling	22
	Annex 4 MODBUS Protocol	23
	Operating diagram (Brief programming)	25

Section1 General

The power factor controller BR6000 is a modern control device of innovative design with a variety of functions.

It features a user interface with a menu-driven display in plain text for maximum ease of operation. Straightforward symbols and alphanumeric displays in the language of the country of use (seven languages) combine maximum ease of handling with convenient presentation of results.

Display of various grid parameters, storage of various values and a test run option make it easy to analyse errors and monitor the system.

An installed base of very high number of PFC controllers underlines the positive acceptance of this product among customers and its high degree of reliability.

Additional features:

- ☑ Six or 12 switching outputs (depending on the version)
- ☑ Switching outputs with a relay or transistor output
- ☑ Twenty pre-programmed control series with a self-optimized intelligent control response
- ☑ Control-series editor for user-defined control series
- ☑ Complete menu-guided operation and display
- ☑ Illuminated graphic display with 2 x 16 characters
- ☑ Four-quadrant operation
- ☑ Display of various line parameters (V, I, F, Q, P, S...)
- ☑ Display of voltage and current harmonics
- ☑ Display of temperature
- ☑ Monitoring of the individual capacitor power values
- ☑ Storage of maximum line-parameter and switching-operation values as well as of the turn-on times of individual capacitor contactors
- ☑ Manual / automatic operation
- ☑ Programming of fixed stages and the option of skipping individual outputs
- ☑ No-voltage turn-off
- ☑ Fault detection for various statuses and interference-message output
- ☑ Test run of PFC system with error analysis
- ☑ Switchboard-integrated housing 144x144x55 mm

Type series and accessories

BR6000-R6 BR6000-T6	6 relays outputs, 1 alarm relay 6 transistor outputs, 1 alarm relay, 2.message relays
BR6000-R12 BR6000-T12	12 relay outputs, 1 alarm relay 12 transistor outputs, 1 alarm relay, 2.message relay
Option /F Option /S	Input for second target cos phi additional user programmable message relay Controller coupling possible As option /F with additional interface RS232 or RS485, MODBUS oder ASCII
Accessories	- Meas. voltage adapter for grids without "N" or voltages above 300V - Current Measuring Module (for measurement of inherent current of capacitor bank) - Remote indication

The controller is supplied as standard for an operating voltage of 230 VAC (L-N), a measuring voltage of 30...300 VAC (L-N) 50/60 Hz and a measuring current of 5A or 1A (programmable). A voltage converter is required for different operating voltages.

Fig. 1 BR6000 front view



- Operating mode
- Automatic
- Programming
- Manual operation
- Service
- Expert mode



Enter / OK
Confirm and store values

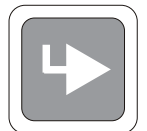

Increase selected parameter



Reduce selected parameter



Fig. 2 BR6000 rear view

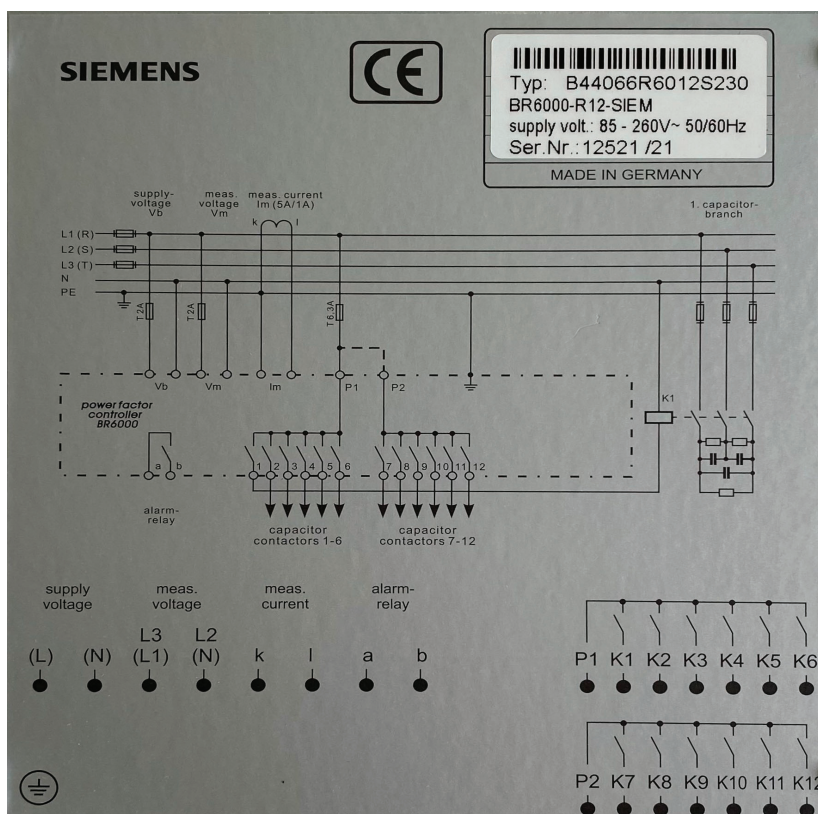

Section 2 Installation and connection of the controller

The BR6000 is designed to be incorporated into the front panel of a PFC-cabinet. It requires a switchboard section of 138 x 138 mm to DIN 43 700. The controller is inserted from the front and is attached by means of the appended clamps. The controller may be inserted only by qualified technicians and must be operated in accordance with the specified safety regulations.

Before the BR6000 is connected up, all leads and cables must be checked to ensure that no current is flowing through them and the current converter must be short-circuited. Care should be taken to ensure that the measuring voltage and current are in the correct phase position. The measuring-current circuit must be wired with copper leads of 2.5mm². The connection should be set up as shown in Fig. 3. The specified safety regulations must be observed.

The measuring voltage may lie in the range from 30 - 300 V and is connected between L1-N (corresponds to 50 - 525 V L-L). A connection between L-L is possible when a measuring-voltage converter is used and the corresponding phase shift U-I is programmed (see Programming).

For higher measuring voltages, a measuring voltage adapter is available as an accessory.

The operating voltage is 230 V +/- 10% and can be connected between L1 - N in a 400-V grid.

The coil voltage for the capacitor contactors and the measuring voltage must be drawn from the same phase conductor, as only the measuring voltage is monitored. (Protection against direct reconnection of the capacitor contactors in the event of momentary single-phase power failure)

Fig. 3: BR6000 Connection plan

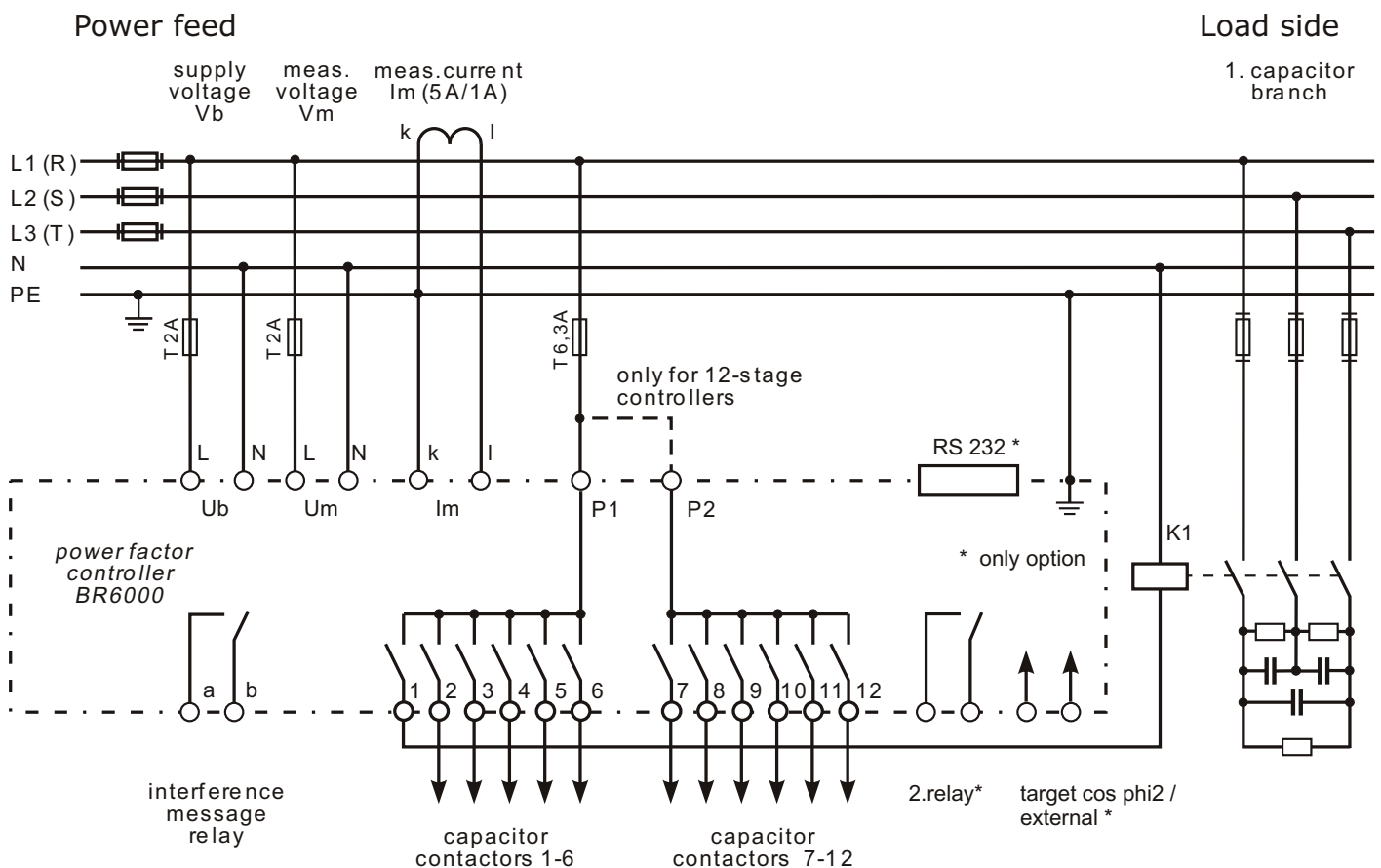

2.1 Current measurement

When installing the current converter, care should be taken to ensure that the load current flows through it. The outputs of the compensation network must be installed behind the current converter (in the direction of current flow). If the BR6000 is connected up via sum-current converters, the overall conversion ratio is entered. Current converter clamps should be grounded on one side!

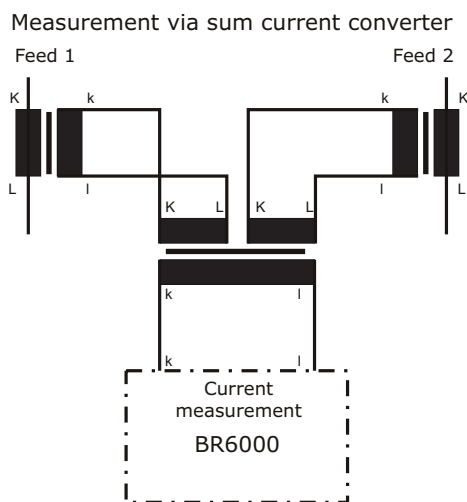

Example:
 C.converter 1: 1000/5A
 C.converter 2: 1000/5A
 Sum-current converter: 5A+5A/5A

 C.converter ratio is: 2000/5A

2.2 Connection of BR6000 in systems differing from Fig.3

Programming of phase-correction between voltage and current in the meas. System

Example:

Meas.current: L1
 Meas. Voltage L3-L2
 (V-converter must be used)

Phase U/I [90°]

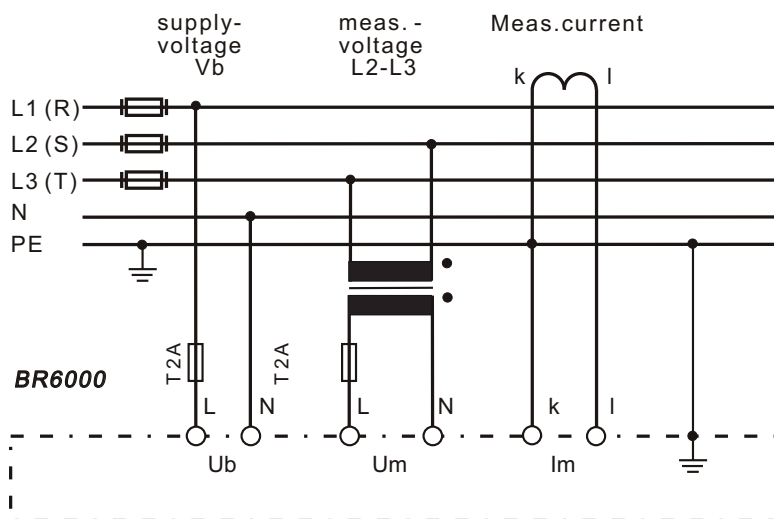

	Meas. Current	meas.voltage	volt.converter	Phase correction
Example 1:	L1	L1 - L2	needed	30°
Example 2:	L1	L3 - L2	needed	90°
Example 3:	L1	L3 - N	no	120°
Example 4:	L1	L3 - L1	needed	150°
Example 5:	L1(k<->I)	L1 - N	no	180°
Example 6:	L1	L2 - N	no	240°
Example 7:	L1 (k<->)	L2 - L3	needed	270°

2.3 Alarm output / fault messages

The alarm contact is closed in normal operation and opens in the event of a fault. The relevant fault is simultaneously shown on the display in plain text (alternating with the standard display in automatic operation). The following fault messages are displayed:

UNDER-COMPENSATED	Display and relay output
OVER-COMPENSATED	Display and relay output
OVERCURRENT	Display and relay output
MEASURING VOLTAGE ?	Display and relay output
OVERTEMPERATURE	Display and relay output
OVERVOLTAGE	Display and relay output
UNDERVOLTAGE	Display and relay output
HARMONICS	Warning / relay programmable
MEASURING CURRENT <	Only display (warning)
SWITCHING OPERATIONS	Only display (warning)

Section 3 Operating modes and programming

When the operating voltage is switched on, the BR6000 briefly displays its designation and software version, then changes to its normal operating status (automatic operation). The active cos-phi value is always displayed in the upper line and the currently connected capacitors are shown as symbols in the lower line (operating display).

Automatic operation

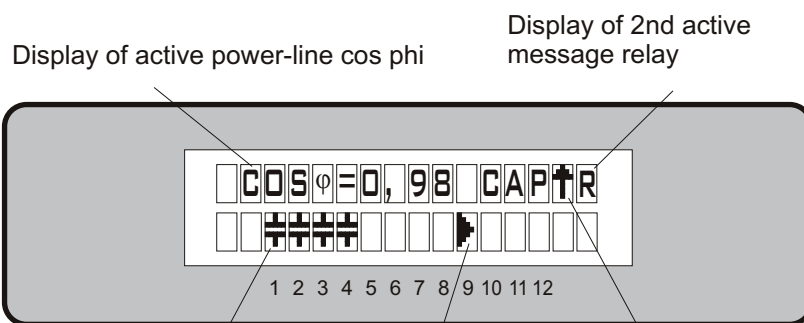

- The control direction is symbolized by a closed arrow
- ▶ Connecting-in
- ◀ Connecting-out
- The connecting-in arrow is always located after the maximum possible number of stages (end stop)
- An open arrow indicates that the required blocking time (discharge time) is running before an impending switching step
- ▶▶ A double arrow symbolizes fast switching of several branches

Active capacitor branches Control direction (here connected-in) Supply display (for 4-quadrant operation)

By pressing the cursor buttons, the display of capacitor stages can be changed:

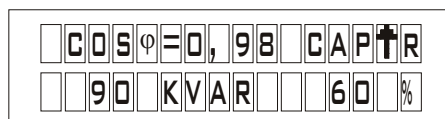

Display of activated stages in kvar and in percent of total output of PFC system

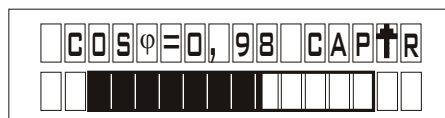

Display of activated stages as bar-graph display in percent of total output of PFC-system

The power values of the individual capacitors are monitored constantly. If a capacitor is defective or if the deviation from the rated power is excessive, the corresponding capacitor is displayed inversely.

Repeated pressing of the "Operating Mode" key takes the user to the various menus in sequence: **Automatic operation - Programming - Manual (manual operation)- Service - Expert mode** and back.

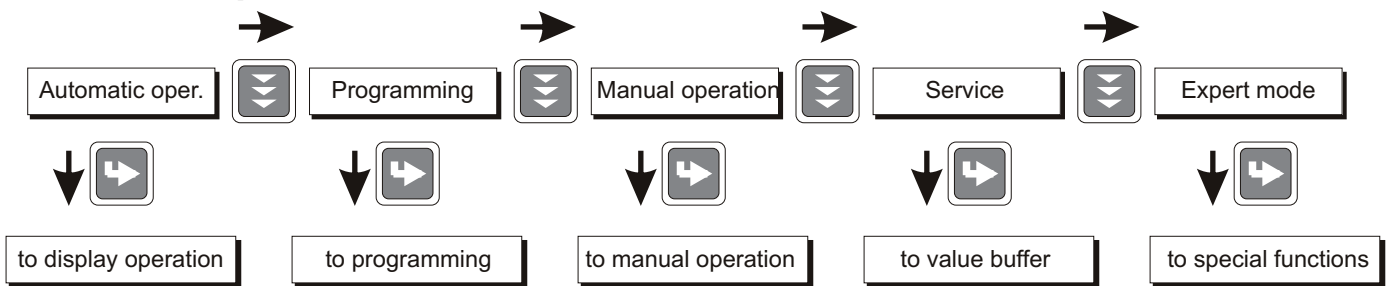

3.1 Automatic operation - display functions

The BR6000 is set to automatic operation as standard. Capacitor stages are then automatically connected in or out in order to reach the target power factor. This happens when the required reactive power exceeds the value of the smallest capacitor stage. In automatic operation, various network parameters can be displayed by repeatedly pressing the "ENTER" key:

Action	Display
ENTER	1 LINE VOLTAGE in V
ENTER	2 APPARENT CURRENT in A
ENTER	3 REACTIVE POWER in kvar
ENTER	4 ACTIVE POWER in kW
ENTER	5 APPARENT POWER in kVA
ENTER	6 DIFF. kVAR TO TARGET COS
ENTER	7 FREQUENCY in Hz
ENTER	8 TEMPERATURE in °C
ENTER	9 HARMONICS (3.-19) V / %, I / % Selection via arrow-keys
ENTER	10 THD-V, THD-I in %
ENTER	Software version
ENTER	Return to: 1

The power value specifies the total power (3-phase) assuming symmetrical load. If no key is pressed for 60 seconds, the display automatically returns to the operating status!

3.2 Programming:



Pressing the "Operating mode" key once takes the user from automatic operation to **Programming** mode. Parameter 1 (I-CONVERTER) is reached by pressing "ENTER". The upper display always shows the parameter and the lower one the set value. The values are changed by pressing the \uparrow / \downarrow keys. Subsequent pressing of the "ENTER" key stores the value and takes the user to the next parameter. To quit programming mode in any step, press the "Operating mode" key.

LANGUAGE SELECTION: This selects the language of the operating menu (German, English, Spanish, Russian, Czech, Dutch, Polish)

1 I-CONVERTER PRIM: This selects the primary current of the current converter. Adjustment is via the \uparrow / \downarrow keys. (5...7500A) Save and continue with ENTER

2 I-CONVERTER SEC: This sets the secondary current of the current converter (5A or 1A possible). Selection via \uparrow / \downarrow . Save and continue with ENTER

3 END STOPP: By setting the end stopp, the number of active capacitor branches is matched to the respective capacitor bank. This is done via the \uparrow / \downarrow keys. The visible symbols of the capacitors correspond to the connected outputs. The maximum possible number of capacitor branches is pre-set at the works (BR6000-R12:12 branches). The setting is confirmed and saved with the ENTER key.

4 CONTROL SERIES: The ratio of the capacitor branch powers determines the control series, the power of the first capacitor always being assigned the value 1. The control series required for the compensation network is again selected via the \uparrow/\downarrow keys. If the required control series should exceptionally not be present (Annex 1), the user may define a special one (control series "E"). More on this point in the control-series editor in Annex 1. The selected series is entered with the ENTER key, which also takes the user to the next step.

5 CONTROL PRINCIPLE: The control preference may be selected here:

SEQUENTIAL connection

LOOP connection

INTELLIGENT loop connection (default setting)

COMBINED CHOKE

See Section 8 for an explanation of the various control modes.

Selection with \uparrow / \downarrow keys and confirmation with ENTER leads to the next point:

6 POWER 1. STAGE: To determine the controller's response sensitivity, the dimensions of the network's smallest capacitor (stage 1) must be known. They are entered in two steps in kvar. The integral kvar values (before the comma) are initially selected via the \uparrow / \downarrow keys and saved with ENTER. The positions after the comma are then selected, again via the \uparrow / \downarrow keys. Saving with the ENTER key leads to the next point.

7 TARGET COS PHI: By setting the target cos phi, the power factor to be attained via the PF correction is defined. It is also set via the \uparrow / \downarrow keys. The range may be selected from 0.8 inductive to 0.8 capacitive. Confirming and saving the value with ENTER leads to the next point.

- 8 MEASURING VOLTAGE:** Programming the measuring voltage (L-N) of the system (direct measurement) or the L-N voltage on the primary side of a measuring-voltage converter. The values programmed here always refer to the voltage L-N in the system! The voltage is selected via the \uparrow/\downarrow keys. Save and continue with ENTER.
- 9 V - CONVERTER RATIO:** Standard setting - NO - (direct measurement) When a measuring-voltage converter (e.g. for HV- measurement) is used, its conversion ratio should be programmed here. Example: Voltage converter 20000V:100 V => Conversion ratio: 200 Selection via the \uparrow/\downarrow keys. Save and continue with ENTER.

Connection of the BR6000 via measuring -voltage converter (L-N)

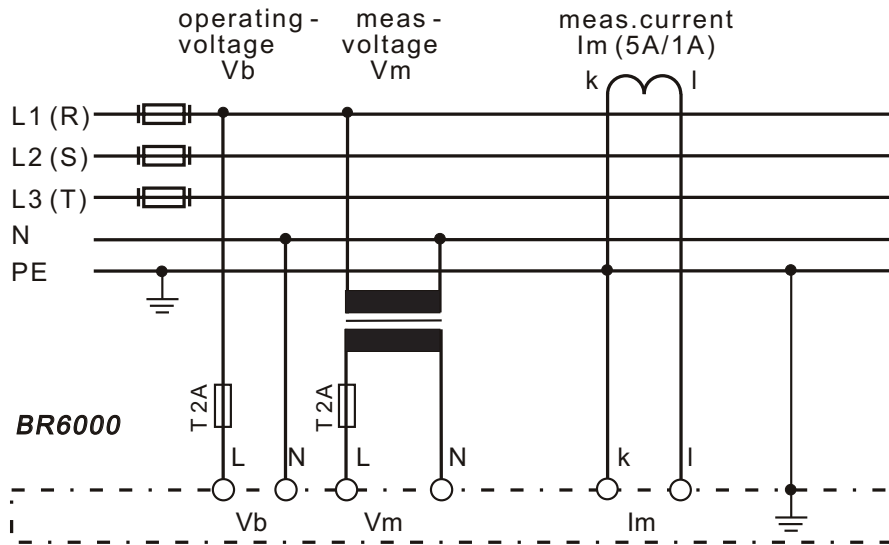

- 10 CONNECTING TIME:** This refers to the time between connecting the capacitors to increase the momentary network capacitance. It should be noted that in practical operation the real connection time is affected by the discharge time (locking time).
 Setting range: 1 sec. ... 20 min. (long time for HV- networks)
 Default setting: 10 sec.
 Selection is performed via the \uparrow/\downarrow keys. Continue with ENTER
- 11 DISCONNECTING TIME:** This refers to the time between disconnecting the capacitors to reduce the momentary network capacitance.
 Setting range: 1 sec. ... 20 min. (long time for HV- networks)
 Default setting: 10 sec.
 Selection is performed via the \uparrow/\downarrow keys. Continue with ENTER
- 12 DISCHARGE TIME:** This is the time for which an individual output is blocked between connecting and disconnecting. This blocking time has priority over connecting and disconnecting times. It depends on the capacitor discharge rating and thus is specified by the compensation network. The discharge time of a conventional network without additional fast-discharge resistors or chokes should be set to no less than 40 seconds.
 For setting of a second discharge time see 'Expert Mode' point 10
 Setting range: 1 sec ...20 min. Default setting: 60 sec.
 Selection is performed via the \uparrow/\downarrow keys. Continue with ENTER

13 ALARM TEMP:

The temperature inside the BR6000 is measured and converted to the internal temperature of the switching cabinet. This value can be shown on the display. The alarm temperature programmed here is the temperature at which the capacitor stages are disconnected in steps. The controller's **alarm relay** responds after ten minutes. At the same time the display shows the cause of the alarm (over-temperature). If the temperature drops again, the required branches are automatically re-connected in steps.

The selection is performed with the \uparrow / \downarrow keys. Save and continue with ENTER.

The following parameters are available only for controllers with the /F or /S options

14 MESSAGE RELAY:

The message relay can be programmed for one of the following options as required:

- "Fan": Relay switches the external cabinet fan.
(Default) The switching threshold can be programmed under point 15.
Display: "R"
- "Supply": Message when active power is supplied. Display: "R"
- "Undercurrent": This message appears whenever the measuring current is not reached. Display: "R" The signal is generated when the value drops below the response sensitivity of the controller.
- "External": The relay switches if an external input signal (230 VAC) is sent to the "cos-phi2 /external" input. This function may be used to directly compensate a larger load, for example - the required 40-second reconnection delay is already integrated.
Display: Capacitor symbol at the top right of the first line.
When this function is selected, the input cannot be used for the signal 'target cos phi2' and the output cannot be used for the fan.
- "Harmonics": This message appears when the limit of the total harmonic distortion THD-V is exceeded. This value can be set under "17 Harmonics" in%
- "Remote control R1": Coupling of two controllers via remote control input, R1= Controller is configured as controller 1 (master)
- "Remote control R2": Coupling of two controllers via remote control input, R2= Controller is configured as controller 2 (slave).
A description for the coupling of two controllers can be found in the annex. When this function is selected, the input cannot be used for the signal 'target cos phi2' and the output cannot be used for the fan.

Selection is via the \uparrow / \downarrow keys. Save and continue with ENTER.

15 and 16 Parameters for message-relay option:

Depending on the programming of the message relay, the following parameters may be selected here:

Fan option: Input of the switching threshold for the fan (30-70°C) Only active when option 'Fan' is selected (temperature input as described under point 13)

Target cos phi2: Input of the second target cos phi as described under point 7, e.g. tariff conversion.

Input signal 230 VAC at input cos phi => target cos phi 2.

At the active input, the display shows: **2** cos φ ...

17 HARMONICS (harmonic limit):

A limit for the total harmonic distortion THD-V (in%) can be entered here. When this threshold is exceeded, a message is given. THD-V is the ratio of the geometric sum of the uneven harmonics to the fundamental. A warning is always shown in the display; an output via message relay only takes place when this was selected under point 14. Selection is performed via the ↑/↓ keys.

Save and continue with ENTER

CONTRAST

The display contrast can be changed with this menu point. The contrast depends to a certain degree on the viewpoint of the observer, i.e. on the insertion height of the equipment in the switching cabinet. The ↑/↓ keys can be used to set an optimal contrast. The contrast changes after a slight delay.

BASIC SETTING: Selection YES / NO

When the selection is made with YES and confirmed with ENTER, all parameters are reset to the basic setting made by the PFC-system manufacturer.

(Optimal network values when the controller was supplied with a complete PFC-system). If the controller is supplied from the works, this point corresponds to the default setting.

CAUTION: All user settings are lost!

Programming is now completed. The controller has returned to point 1 of the programming menu.

3.3 Programming lock

The BR6000 is equipped with a programming lock to ensure protection from unauthorized or inadvertent changes to the system parameters. The lock can be activated in expert mode. If the lock is active, all parameters can be checked but not changed.

**Section 4 Manual operation (initial operation, maintenance, service)
Programming of fixed stages**

In manual operation, capacitor branches can be connected/disconnected **in the set control series and switching time** - irrespective of prevailing power-line conditions. The starting condition is STOPP (no stages connected). Connections are made by pressing the ↑ key. Pressing ↓ initially leads back to STOPP mode. Repeated pressing of ↓ leads to the disconnection of stages. The active operating status and active power factor are always shown on the display (self-explanatory).

Manual operation

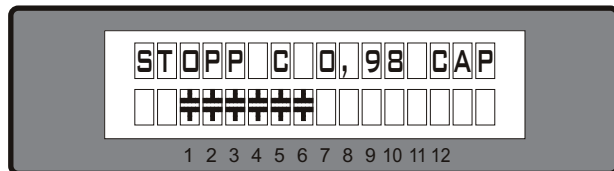

Pressing ENTER takes the user to the menu point "Programming of fixed stages". In the normal case, all stages are programmed for automatic operation (default setting).

Setting of fixed stages

Currently selected stage blinks

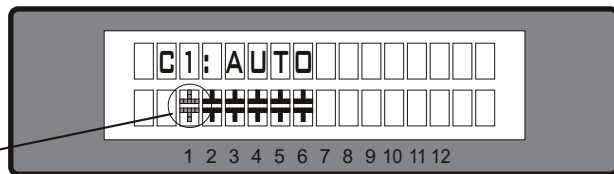

In special cases, all controller outputs (C1 - C12) may be permanently defined in succession (continued switching via ENTER) for the following statuses:

AUTO: Automatic (normal) operation

The relevant output is marked by a capacitor symbol.

FIXED: The output is continuously connected, e.g. for fixed PFC. The output is marked by an underlined capacitor symbol.

OFF: The output is continuously disconnected - e.g. for temporarily disconnecting a defective capacitor. The capacitor symbol for this output is faded out. Underlining appears.

The active stage is marked by blinking. The required status is set via ↑ / ↓. By pressing ENTER, the user saves this step and moves to the next stage.

The programmed statuses for the outputs also remain visible on the display in automatic operation.

After the required settings have been made, pressing the "Operating Mode" key takes the user to the next menu ("Service") or further to "Automatic Operation".

Section 5 Service menu

The service menu is reached by the operating-mode key.

The stored maximum values of the network parameters can be displayed here as well as the number of switching operations of the individual capacitors and their operating time. The desired stages [in square brackets] can be selected via the arrow keys.

In addition, a fault memory is available, in which the last 8 fault states of the system are stored with fault code and in plain text. (This allows, for example, capturing short lived events of overtemperature or overvoltage)

Action	Display
ENTER	1 max. VOLTAGE in V
ENTER	2 max. REACTIVE POWER in kvar
ENTER	3 max. ACTIVE POWER in kW
ENTER	4 max. APPARENT POWER in kVA
ENTER	5 max. TEMPERATURE in °C
ENTER	6 max. THD - V / THD - I in %
ENTER	7 RESET the maximum values
ENTER	8 SWITCHING OPERATIONS C [1] - ...
+/-	to C [12]
ENTER	9 OPERATING TIME C [1] - ... in h
+/-	to C [12]
ENTER	FAULT MEMORY E [1] - in plaintext
ENTER	FAULT MEMORY RESET
ENTER	TEST RUN
ENTER	C-output
ENTER	Back to 1

TEST-RUN

This menu point allows the user to check the settings of the PFC controller. After activation of the test run, the controller switches each stage on and off successively and calculates the output of the capacitors connected (this procedure is done three times to eliminate possible errors). The values calculated are stored and can be retrieved in the following menu item (C-output). At the same time, a plausibility check is conducted with the values programmed.

Any discrepancies found are evaluated and displayed in plain text. The following errors can be displayed:

- No measuring voltage present
- Measuring voltage too high - check programming
- Measuring voltage too low - check programming
- No measuring current? - Short circuit link in current transformer?
- Phase angle current transformer? K/I or phase transposed ?
- Current transformer ratio / 1. Step power wrong ?
- Control series? - check programming
- End stop? - check programming
- Capacitor defect or wrong power input

Note: The results displayed are messages intended to help the user trace the cause of the error. Final evaluation remains the responsibility of the user. Under complicated (high load fluctuations) grid conditions, 100% error recognition cannot be guaranteed.

Section 6 Expert mode

Expert mode is used to set values which remain unchanged for normal operation. This level has an access code to protect it from improper operation.

1: PASSWORD 6343

2 BASIC SETTING NEW [NO] (available: NO/YES)
Storage of active programming as a new basic setting (usually performed by the PFC-system manufacturer). Caution: The original values are overwritten in the process!

3 SWITCHING OPERATIONS RESET [NO] (available: NO/YES)
The stored switching operations of the capacitor stages are reset to zero. Caution: No information is then available about the switching frequency of the stages and thus the status of the network.

4 OPERATING TIME RESET [NO] (available: NO/YES)
The stored operating times of the individual outputs are set to zero.

5 INTEGRATION TIME [1] s (1...255 sec.)
The integration time (the time required to form the mean values of a measurement) can be changed for special applications.

6 C/k- FACTOR [0.66] (0.4...0.9)
The C/k value calculated from the programmed network values can be matched by changing this factor. It should not be changed in the normal case!

7 SWITCHING POWER max [100] kvar (multiples of the smallest stage)
This factor specifies the maximum power which may be switched in one switching step. It can be used to control the intelligent control system, which switches several stages as a function of the power-factor requirement.

8 OPERATING LOCK [NO] (NO / YES / 24H)

9 SWITCHING OPERATIONS WARNING [10] T (1...255)
After an output has performed this number of switching operations (in thousands), a warning message is displayed.

10 FAST DISCHARGE [NO] (NO or X for the desired stages)
If only some stages of a network are equipped with fast discharge equipment, those stages can here be indicated with X. In this case, the desired discharge time for these stages can be specified in the next menu point. Otherwise, menu point 11 is omitted.

11 DISCHARGE TIME [1] s (1s ..programmed normal discharge time)
Only available when fast discharge is programmed. The specified discharge time is then also included in the normal display.

12 PHASE V/I [0 °] (0°, 30°, 90°, 120°, 150°, 180°, 240°, 270°)
Phase correction between voltage and current in the measuring system.
(See example p.6)
This setting allows to measure also in systems without neutral. However, the measuring voltage must not exceed 300 V (if necessary, a voltage converter must be used).

- 13 C-TEST** [YES] (YES / NO)
The power of the particular capacitor stage is calculated during each switching operation and compared with the stage output of the capacitor. If the result varies from the nominal value, an error message is generated. This test can be stopped here.
- 14 C-FAULT** [40] % (10...75 %)
The deviation from the rated value of the capacitor, for which a fault message is generated, can be specified here (see point 13)
- 15 TEST ATTEMPTS** [5] (2...9)
When at least this number of successive measurements has resulted in a fault in the capacitor power, a C-fault message is output.
- 16 OUTPUT 1.STEP** [0...255] (0...2550)
The range for entering the stage output can be increased to [0...2550] here, (e.g. for medium voltage measurement)
- 17 CONTROL [3] PHASE** (3 / 1)
The measuring system of the controller is generally based on single-phase measurement. For all standard settings (three-phase), the measurement is converted and all outputs displayed as three-phase values (symmetry in grid assumed). In the single-phase setting, display and control apply only to the single-phase value measured (application: single-phase correction in asymmetrical grids).

Interface settings (only option .../S)

18 BAUD RATE	[9600]	(4800...38400)	Transmission rate
19 PROTOCOL	[MODBUS]	(Modbus or ASCII)	Transmission protocol
20 ADDRESS	[1]	(1...32)	Address

Section 7 Initial operation

The controller must have been installed before being set up and operated. All network-specific parameters are fully programmed as described in Section 3.2 (Programming) by being entered in sequence and stored. The controller is then set to automatic operation with the operating mode key. It is now ready for operation.

Section 8 Control principle

The control response of the BR6000 can be selected in programming mode. In principle, the controller has four different control modes:

1. Sequential connection

In sequential connection, the required capacitor stages are successively connected and disconnected in stages (last in - first out). The ranking of each step always corresponds to the power of the smallest stage.

Advantage: Exact definition of the next capacitor to be connected in each case

Disadvantage: Long settling time, high switching frequency of the small stages

In order to shorten the settling time, the BR6000 switches several stages simultaneously for a large power-factor requirement. This applies to all control types. The maximum dimensions of the simultaneously switching branches can be changed in expert mode. If the value of the smallest stage is pre-selected, the conventional sequential connection is obtained.

2. Loop connection

In this variant, the controller operates in loop mode (first in - first out) which minimizes the wear on the capacitor bank, i.e. where stages are of equivalent dimensions, the stage which was disconnected for the longest period of time is always connected next.

Advantage: Balanced utilization of equivalent stages and thus an increased operating life of the capacitor bank.

Disadvantage: This mode can only be used in control series with groups of the same stage power and long settling time, as every switching step corresponds to the value of the smallest stage.

3. Intelligent loop connection (default setting)

The intelligent control principle combines the advantages of the network-sparing loop connection (first in - first out) with a much faster settling time, even for large load skips, and reaches this goal with the fewest possible switching operations of the capacitor stages. The optimized time response is achieved by the simultaneous switching of several or larger capacitor groups as a function of the missing power factor in the power line. Both the number of real switching frequencies of the capacitors as well as the turn-on times of the branches are considered.

Advantage: Reaches the target cos phi in a fast-optimized settling time with a low switching frequency of the capacitors.

4. Combined de-tuning (special case for combined de-tuned banks)

Within a combined de-tuned application, 2 adjoining equal steps are switched with just one joint choke. This pairwise de-tuning requires an appropriate closed control series (i.e. 1:1:1:1..., 1:1:2:2..., 1:1:2:2:4:4... or similar)

The condition for the switching behavior is defined in such a way that the number of activated odd steps is always greater than or equal to the number of activated even steps. The controller complies with the requirements of the control regime while largely conforming to the intelligent switching behavior.

Section 9 Interface *

The BR6000 is equipped with an RS 232 or RS 485 interface as an option.

It can be used to implement the following functions:

- Full parametrization of the controller via a PC
- Remote read-out of all operating statuses and displays via a PC
- Connection of a remote display (system accessories) for clear read-out of all measurements on large seven-segment triple displays
- Selection of MODBUS or ASCII (permanent display of grid parameters in ASCII format). Any ASCII editor can be used. The following data is permanently displayed and refreshed every second:
1 voltage, 2 current, 3 reactive power, 4 active power, 5 apparent power
6 frequency, 7 power factor (cos Phi), 8 status of outputs

Section 10 Maintenance and warranty

The BR6000 should need no maintenance if the operating conditions are observed. However, it is recommended that a functional check of the controller be performed in conjunction with the regular checking of the capacitor bank. In the event of any interventions in the controller during the warranty period, all warranty claims lapse.

Section 11 Troubleshooting

Fault	Check / Solution
At target $\cos \phi=1$ and inductive load, switch-off or connection of capacitor in the corrected line Supply / Drawing mismatched	Check terminals of the measuring voltage and current (l and k)! Check phase position
Wrong line $\cos \phi$ is displayed	See above
Display: "UNDER CURRENT"	Current in measuring range? Line interruption? Wrong current-converter factor? Current transformer short-circuited?
Display: "OVERCURRENT" Alarm relay: after 10 min.	Check current-converter ratio Go through measuring current range
Display: "UNDERCOMPENSATED" Alarm relay: after 10 min.	Check connection and phase position! All stages connected - target $\cos \phi$ not reached: compensation network sufficiently dimensioned?
Display: "OVERCOMPENSATED" Alarm relay: after 10 min.	Check connection and phase position! Capacitive grid, although all stages disconnected
Display: "MEASUREMENT VOLTAGE ???" Alarm relay: after 10 min.	No measurement voltage!
Display: "OVERTEMPERATURE" Alarm relay: after 10 min.	Cabinet temperature too high: Outputs are switched off in stages irrespective of power-line conditions
Stages are disconnected for an inductive line or connected for a capacitive line	If a target $\cos \phi$ is set which deviates from 1 despite an inductive line load, the display <- (disconnect stages) may light up. The arrows indicate the control direction and not the line conditions.
The controller does not connect all stages, or $\cos \phi$ does not change at the last stages	Check END STOPP!
In automatic operation, individual stages are not connected or disconnected:	Check whether individual stages are programmed as fixed stages or OFF in the "Manual operation / Fixed stages" menu!
In strongly asymmetrically loaded lines, differences may occur between control response and power-factor measurement, as the power factor is measured in single phase.	Line measurements allow the most favorable phase for measuring the power factor to be determined. The current converter is set accordingly for the measuring current.
No operating voltage	Note: No display, alarm relay is closed

12 Technical data

Type series	BR6000....
Outputs	6 / 12
Languages	G / E / ES / RU / NL / CZ / PL
Switching power of relay outputs	250 VAC, 1000 W
Number of active outputs	Programmable
Operation and display	Illuminated graphic display 2 x 16 characters with convenient operating level
Number of control series	20
User-defined control series	1
Control principle	Selectable Sequential connection, loop connection or self-optimized switching response Four-quadrant operation
Operating voltage	230 VAC, 50 / 60Hz
Measuring voltage	30...300 VAC (L-N), 50 / 60Hz Phase - shift possible
Measuring current	X : 5 / 1A selectable
Power drawn	< 5 VA
Sensitivity	50 mA / 10 mA
Target cos phi	0.8 inductive to 0.8 capacitive adjustable
Connecting time	Selectable from 1 sec ... 20 min.
Disconnecting time	Selectable from 1 sec ... 20 min.
Discharge time	Selectable from 1 sec ... 20 min.
Fixed stages/ skipped stages	Programmable
Alarm relay	Standard
No-voltage triggering	Standard
Display of power-line parameters	Voltage, apparent current, frequency, power factor, active power, apparent power, missing kvar, temperature, harmonics
Storage of maximum values	Voltage, power factor, active power, apparent power, temperature, THD-V, THD-I
Storage of switching number	Yes, each output
Storage of operating time	Yes, each capacitor
Fault Memory	Last 8 fault states are stored
Temperature measurement range	0 - 100°C
Housing	Switchboard-integrated housing DIN 43 700, 144 x 144 x 53 mm
Weight	1 kg
Operating ambient temperature	-10 to +60°C
Protection type to DIN 40 050	Front: IP 54, Rear: IP 20
OPTIONS:	
Option /F	Input for second target cos phi additional user programmable message relay Controller coupling possible
Option /S 232 (485)	As option /F with additional interface RS232 or RS485
Option: Measurement of inherent current Of capacitor bank	Current measurement module available as accessory, to be connected via interface

Annex 1: Table of control series

No.	Control series	Loop connection
1	1:1:1:1:1:1:1:1:1:1:1:1	Possible
2	1:2:2:2:2:2:2:2:2:2:2:2	Possible
3	1:2:3:3:3:3:3:3:3:3:3:3	Possible
4	1:2:3:4:4:4:4:4:4:4:4:4	Possible
5	1:2:4:4:4:4:4:4:4:4:4:4	Possible
6	1:2:3:6:6:6:6:6:6:6:6:6	Possible
7	1:2:4:8:8:8:8:8:8:8:8:8	Possible
8	1:1:1:1:2:2:2:2:2:2:2:2	Possible
9	1:1:1:1:1:6:6:6:6:6:6:6	Possible
10	1:1:2:2:2:2:2:2:2:2:2:2	Possible
11	1:1:2:2:2:4:4:4:4:4:4:4	Possible
12	1:1:2:2:4:4:4:4:4:4:4:4	Possible
13	1:1:1:2:2:2:2:2:2:2:2:2	Possible
14	1:1:2:3:3:3:3:3:3:3:3:3	Possible
15	1:1:2:4:4:4:4:4:4:4:4:4	Possible
16	1:1:2:4:8:8:8:8:8:8:8:8	Possible
17	1:2:2:3:3:3:3:3:3:3:3:3	Possible
18	1:2:3:4:4:8:8:8:8:8:8:8	Possible
19	1:2:2:4:4:4:4:4:4:4:4:4	Possible
20	1:2:2:2:4:4:4:4:4:4:4:4	Possible
"E"	Control-series editor	Possible

Control -series editor (programming up to a rating of 20)

The control-series editor allows the user to simply define his/her own control series if the required control series is not available for any reason.

The last control series - Control Series E - is selected by pressing the "Programming" key (point 4: Control series) and confirmed with ENTER. This leads to the insertion of an additional menu point in the main menu -> the control-series editor. It may be reached via the "Operating Mode" key.



In the control-series editor, all stages can be set in succession to the desired value with the selection keys \uparrow / \downarrow . The next stage in each case is reached by pressing ENTER. An intelligent pre-selection of the stages is integrated, so that only "meaningful" control series can be generated. The maximum number of stages can be limited by a programmed END STOPP < 12.

NEW: In the control series editor, the various steps may be programmed up to a rating of 20 (!). The rating >9 is indicated in the display as follows:

10=A, 11=B, 12=C, 13=D, 14=E, 15=F, 16=G, 17=H, 18=I, 19=J, 20=K

The user may quit the editor with the "Operating Mode" key.

Annex 2: Default settings

Note: The following values for the default settings apply only if the controller is supplied directly from the works. Otherwise, these values are replaced by the basic settings made by the manufacturer of the compensation network (optimal values for the relevant network).

No.	Parameter	Default setting	Programmed values of this network (to be entered by network manufacturer or operator)
0	LANGUAGE	ENGLISH	Cannot be changed
1	I CONVERTER prim.	1000 A	
2	I CONVERTER sec.	5 A	
3	END STOPP	12 (6)	
4	CONTROL SERIES	1	
5	CONTROL PRINCIPLE	INTELLIGENT	
6	POWER 1. STAGE	25.00 kvar	
7	TARGET COS-PHI	0.98 IND	
8	MEASURING VOLTAGE	230 V L-N	
9	V- CONVERTER RATIO	- NO -	
10	SWITCH- IN TIME	10 sec.	
11	SWITCH- OFF TIME	10 sec.	
12	DISCHARGE TIME	60 sec.	
13	ALARM TEMP.	55 °C	
14	MESSAGE RELAY *	FAN	
15	TEMP. FAN ON	30 °C	
16	TARGET COS-PHI 2	0,95 IND	
17	HARMONICS THD-V	7,0 %	
	CONTRAST	- 7 -	
	Capacitor stages	AUTO	
	Password	6343	
	Integration time	1 sec.	
	C/k constant	0.66	
	Max. simultaneous switching power	4 x smallest stage power	
	Operating lock	- NO -	
	Switching operations warning	10,000	
	Fast discharge	- NO -	
	Phase shift U/I	0 °	
	C - Test	- YES -	
	C - Fail	40 %	
	Test Attempts	5	
	Power 1. stage	0...255 kvar	
	Control	3 - phase	
	Baudrate*	9600	
	Protocol*	MODBUS	
	Address*	1	

Annex 3: Controller coupling (Programming under "14 message relay")

For example, coupling is useful when two separate installations are operating on two transformer supplies and a coupling exists for both systems. When the coupling is closed (because only one supply is working), it is still possible to access the total compensation power of both installations via the coupling of the controllers. The network is then operating in master-slave mode. When all stages of the first controller are connected, the second controller is taking over and switches the remaining stages.

It is therefore also possible to extend networks easily.

When coupling is requested, it is necessary to program "controller1" (as master) or "controller2" (as slave) in this menu point.

For coupling, the controllers of the two installations have to be connected as follows:

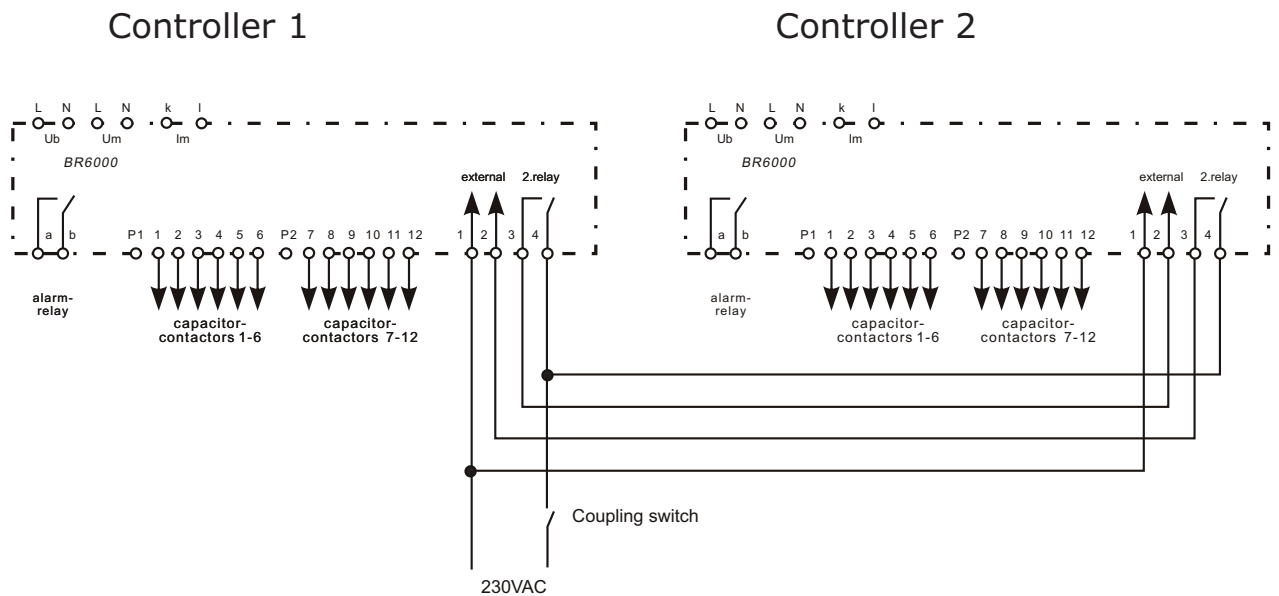

When the coupling switch is open, both installations are operating independently. When the coupling is closed, master-slave operation is initiated automatically.

It is an advantage of this simple solution that an additional serial interface is not required.

NOTE: By coupling a BR6000 with a dynamic controller (BR6000-T), a mixed dynamic system can be designed that implements economically the advantages of a dynamic fast network. (Fast changing loads are compensated dynamically and basic loads and slowly changing loads are compensated conventionally):

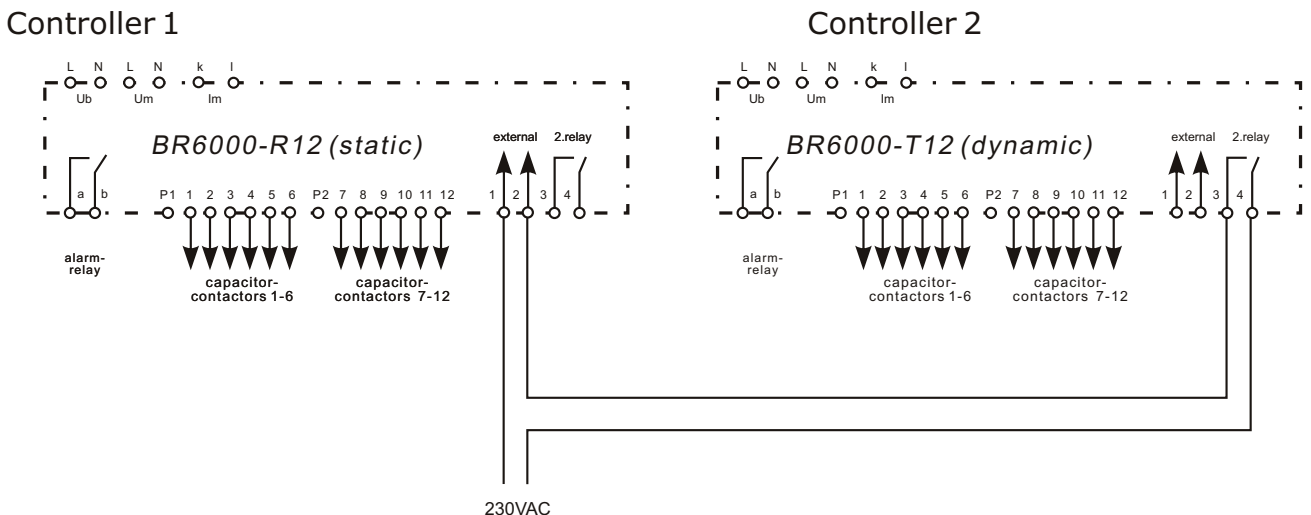

Annex 4: MODBUS-Protocol - Part 1: only read -register

F	Modbus No	Register / Function	Range	unit / digit	BR6000
3	0	Reactive Pwr H-Part	32 Bit Long	1 var	A - 3
	1	Reactive Pwr L-Part			
	2	Active Power H-Part	32 Bit Long	1 W	A - 4
	3	Active Power L-Part			
	4	Apparent Pwr H-Part	32 Bit Long	1 VA	A - 5
	5	Apparent Pwr L-Part			
	6	Diff.React.Pwr H-Part	32 Bit Long	1 var	A - 6
	7	Diff.React.Pwr L-Part			
	8	Actual system output (in var)	32 Bit Long	1 var	
	9				
	10	Actual system output (in %)	16 Bit	1 %	
	11	Voltage with resolution of 0.1V (max 300V)	16 Bit	0,1 V	
	12	Current with resolution of 0.1 A	32 Bit Long	0,1 A	
	13				
	14	Voltage with resolution of 0.1V	32 Bit Long	0,1 V	
	15	(e.g. 2314 = 231,4 V)			
	20	Line voltage	16 Bit	1 V	A - 1
	21	Apparent current	16 Bit	1 A	A - 2
	22	Frequency	16 Bit	1 Hz	A - 7
	23	Temperature (cabinet)	16 Bit	1 °C	A - 8
	24	Temperature (controller)	16 Bit	1 °C	System
	30	Outputs (relays)	16 Bit	Bit1= Rel 1	A - 0
	31	3. Harmonics – voltage	16 Bit	0,1 %	A9.1
	32	5. Harmonics – voltage			A9.2
	33	7. Harmonics – voltage			A9.3
	34	9. Harmonics – voltage			A9.4
	35	11. Harmonics – voltage			A9.5
	36	13. Harmonics – voltage			A9.6
	37	15. Harmonics – voltage			A9.7
	38	17. Harmonics – voltage			A9.8
	39	19. Harmonics – voltage			A9.9
	40	THD – voltage	16 Bit	0,1 %	A-10
	41	3.Harmonics – current	16 Bit	0,1 %	A9.1
	42	5.Harmonics – current			A9.2
	43	7.Harmonics – current			A9.3
	44	9.Harmonics – current			A9.4
	45	11.Harmonics – current			A9.5
	46	13.Harmonics – current			A9.6
	47	15.Harmonics – current			A9.7
	48	17.Harmonics – current			A9.8
	49	19.Harmonics – current			A9.9
	50	THD – current	16 Bit	0,1 %	A-10
	51	Cos Phi (100=1.00)	16 Bit	0.01	A - 0
	60	Failure - register	16 Bit	Bit 0-7	A - 0
	61	Warning - register	16 Bit	Bit 0-7	A - 0
	71...82	Relays 1...12	16 Bit	0 = OFF 1 = ON	
	101	Language	0 – 2	1=English	P – 0
	102	I - Converter primary	0 – 255	0=5A...	P – 1
	103	I - Converter secondary	6 – 7	6=1A...	P – 2
	104	Endstopp	1 – 12		P – 3
	105	Control series	1 – 21		P – 4
	106	Control mode	12 – 15	12=Sequ..	P – 5
	107	Power First Stage 1	0 – 255		P – 6.0
	108	Power First Stage 2	0 – 99		P – 6.1
	109	Target cos-Phi 1	80 – 120	80=0,8cap.	P – 7
	110	Meas. Voltage	29 – 255	Volt	P – 8
	111	Voltage converter ratio	1 – 126	Ratio	P – 9
	112	Switching – ON Time	1 – 138	Sec / min	P – 10
	113	Switching – OFF Time	1 – 138	Sec / min	P – 11
	114	Discharge Time	1 – 138	Sec / min	P – 12
	115	Alarm temperature	50 – 85	°C	P – 13
	116	Message relay	19 – 25	19=extern..	P – 14
	117	FAN temperature	30 – 70	°C	P – 15
	118	Target cos-Phi 2	80 – 120	80=0,8cap.	P – 16
	119	Harmonics THD-voltage	5 – 200	5=0,5%...	P – 17
	120	Contrast	0 – 10		P
	121	Basic settings	0 – 1	0=No	P
	131...142	Rating step 1...12	16 Bit	0 - 9	
	151...162	Status: 1 – OFF 2 – AUTO 3 – FIXED	16 Bit	1 - 3	Manual
	170	Control direction: 1 - C – 2 - STOPP 3 - C+	16 Bit	1 - 3	
	171	Max. switching power	16 Bit	1 - 9	Ex
	181...191	Discharge time C1 ... C12	16 Bit	1 s	-----

Part 2: - only – write - register:

F	Modbus No	Register / Function	Range	unit / digit	BR6000
6	1	Language	0 – 2	1=English	P – 0
	2	I - Converter primary	0 – 255	0=5A...	P – 1
	3	I - Converter secondary	6 – 7	6=1A...	P – 2
	4	Endstopp	1 – 12		P – 3
	5	Control series	1 – 21		P – 4
	6	Control mode	12 – 15	12=Sequ..	P – 5
	7	Power First Stage 1	0 – 255		P – 6.0
	8	Power First Stage 2	0 – 99		P – 6.1
	9	Target cos-Phi 1	80 – 120	80=0,8cap.	P – 7
	10	Meas. Voltage	29 – 255	Volt	P – 8
	11	Voltage converter ratio	1 – 126	Ratio	P – 9
	12	Switching – ON Time	1 – 138	Sec / min	P – 10
	13	Switching – OFF Time	1 – 138	Sec / min	P – 11
	14	Discharge Time	1 – 138	Sec / min	P – 12
	15	Alarm temperature	50 – 85	°C	P – 13
	16	Message relay	19 – 25	19=extern..	P – 14
	17	FAN temperature	30 – 70	°C	P – 15
	18	Target cos-Phi 2	80 – 120	80=0,8cap.	P – 16
	19	Harmonics THD-voltage	5 – 200	5=0,5%...	P – 17
	20	Limit value PFC system			
	21	Contrast	0 – 10		P
	22	Basic settings	0 – 1	0=No	P
	40	Remote control Register value H = Data 1 (switch.power max- multiples of the smallest stage)	8 Bit	1 – 9 (1 – 4)	
		Register value L = Data 2 0 – Remote OFF 1 – Switching DOWN 2 – Stopp 3 – Switching UP	8 Bit	0 – 3	

Part 3 example:

MODBUS – Functioncode 3 (only read - register ..)

example: Meas. voltage

answer

Byte 1:	Slave adress	1	Slave adress	1
Byte 2:	Functioncode	3	Functioncode	3
Byte 3:	Reg.startadress „H“:	0	Number of Bytes	2
Byte 4:	Reg.startadress „L“:	20	Data H	0
Byte 5:	Reg.Number „H“:	0	Data L	233
Byte 6:	Reg.Number „L“:	1		
Byte 7:	CRC Prüfcode „L“	196	CRC L	121
Byte 8:	CRC Prüfcode „H“	14	CRC H	202

MODBUS – Functioncode 6 (only write - register)

example: Remote control (Remote switching-up)

answer

Byte 1:	Slave adress	1	1
Byte 2:	Functioncode	6	6
Byte 3:	Registeradress „H“:	0	0
Byte 4:	Registeradress „L“:	40	40
Byte 5:	Reg.value „H“(Data1):	1	1
Byte 6:	Reg.value „L“(Data2):	3	3
Byte 7:	CRC Prüfcode „L“	72	72
Byte 8:	CRC Prüfcode „H“	83	83

Reg.value 1 = Switching - up with max. 1 Step (1)
Reg.value 3 = Remote switching - up (3)

Part 4 Usage of the interface:

Due to the priority of the control function of the power factor controller before data exchange, please consider that per command 12 consecutive values maximum (s. table) are transferred blockwise.
Also, parameters should not be retrieved more than 1 x /second.

Settings: 8 data bit, 1 stop bit, no parity

In "Expert Mode" \17 Protocol" there are 2 types of Modbus-control:

[MODBUS] Modbus without check (default) - there is no warning, if no valid answer from slave is given
[MODBUS KTR] Modbus with check of valid answer from slave - a warning "MODBUS ERROR" will shown on display, if no valid answer from slave is given within 4 minutes.

For MODBUS KTR: no adjustment of program memory (security interlock)

By pressing the cursor buttons (up / down) the stage display mode can be changed

AUTO MODE

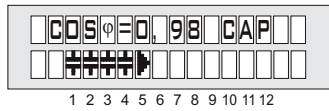

In case of error alternating display between error and cos Phi

- UNDERCOMPENSATED
- OVER-COMPENSATED
- UNDERCURRENT
- OVERCURRENT
- UNDERVOLTAGE
- MEAS. VOLTAGE ???
- OVERTEMPERATURE
- OVERVOLTAGE
- HARMONICS !
- SWITCHING OPERATIONS

- 1 LINE VOLTAGE
400,0 V
- 2 APPARENT CURRENT
88,88 A
- 3 REACTIVE POWER
88,88 kvar
- 4 ACTIVE POWER
88,88 kW
- 5 APPARENT POWER
88,88 kVA
- 6 DIFF REACT POWER
88,88 kvar
- 7 FREQUENCY
50,0 Hz
- 8 TEMPERATURE
25,0°C
- 9 HARMONICS [3]
U: 0,5% - I: 0,1%
- 10 HARMONICS THD
U: 0,5% I: 0,3%
- SOFTWARE
VERSION 3.0 / E
- RETURN TO 1

After 60 sec. without pressing any button, automatic change to auto-mode



PROGRAMMING

- 0 LANGUAGE
ENGLISH
- 1 I-CT PRIMARY
[1000] A / X
- 2 I-CT SECONDARY
1000 / [5] A
- 3 END STOPP

- 4 CONTROL SERIES
1 1 1 1 1 1 1 1 1 1 1 1
- 5 CONTROL MODE
[INTELLIGENT]
- 6 POWER 1.STAGE
[25], 00 kvar
- 7 TARGET COS PHI
[0,8] IND
- 8 MEAS.VOLTAGE
[230] V L-N
- 9 V - CT RATIO
- NO -
- 10 SWITCH - IN TIME
[10] s
- 11 SWITCH - OFF TIME
[10] s
- 12 DISCHARGE TIME
[60] s
- 13 ALARM TEMP.
[55 °C]
- 14 MESSAGE RELAY *
[FAN]
- 15 FAN TEMP.
[30 °C]



CONTROL SERIES EDITOR

only available if control serie "E" is selected

- KVAR-RATIO C 2
1 ① 2 2 2 2 2 2 2 2 2 2 2 2
- KVAR-RATIO C 3
1 1 ② 2 2 2 2 2 2 2 2 2 2
- KVAR-RATIO C 4
1 1 2 ② 2 2 2 2 2 2 2 2
- KVAR-RATIO C 5
1 1 2 2 ② 2 2 2 2 2 2 2 2
- up to capacitor 6 / 12
- KVAR-RATIO C 12
1 1 2 2 2 2 2 2 2 2 2 ②
- RETURN TO 1
- 16 TARGET COS PHI 2
[0,95] ind
- 17 HARMONICS THD-V [7] %
- CONTRAST
- 9 -
- BASIC SETTINGS
RESET - NO -
- BACK TO 1

Changing of values by buttons:



