

SIEMENS



Manual

SENTRON

7KM Power Monitoring Device

PAC3120 and PAC3220

Edition

10/2019

[siemens.com/SENTRON](https://www.siemens.com/SENTRON)

SIEMENS

SENTRON

Power Monitoring Device 7KM PAC3120 and PAC3220



Equipment Manual

<u>Introduction</u>	1
<u>Description</u>	2
<u>Mounting</u>	3
<u>Connection</u>	4
<u>Commissioning</u>	5
<u>Operator control</u>	6
<u>Parameter assignment</u>	7
<u>Security features</u>	8
<u>Service and maintenance</u>	9
<u>Technical data</u>	10
<u>Dimensional drawings</u>	11
<u>Appendix</u>	A

Legal information

Warning notice system

This manual contains notices you have to observe in order to ensure your personal safety, as well as to prevent damage to property. The notices referring to your personal safety are highlighted in the manual by a safety alert symbol, notices referring only to property damage have no safety alert symbol. These notices shown below are graded according to the degree of danger.

 DANGER
indicates that death or severe personal injury will result if proper precautions are not taken.
 WARNING
indicates that death or severe personal injury may result if proper precautions are not taken.
 CAUTION
indicates that minor personal injury can result if proper precautions are not taken.
NOTICE
indicates that property damage can result if proper precautions are not taken.

If more than one degree of danger is present, the warning notice representing the highest degree of danger will be used. A notice warning of injury to persons with a safety alert symbol may also include a warning relating to property damage.

Qualified Personnel

The product/system described in this documentation may be operated only by **personnel qualified** for the specific task in accordance with the relevant documentation, in particular its warning notices and safety instructions. Qualified personnel are those who, based on their training and experience, are capable of identifying risks and avoiding potential hazards when working with these products/systems.

Proper use of Siemens products

Note the following:

 WARNING
Siemens products may only be used for the applications described in the catalog and in the relevant technical documentation. If products and components from other manufacturers are used, these must be recommended or approved by Siemens. Proper transport, storage, installation, assembly, commissioning, operation and maintenance are required to ensure that the products operate safely and without any problems. The permissible ambient conditions must be complied with. The information in the relevant documentation must be observed.

Trademarks

All names identified by ® are registered trademarks of Siemens AG. The remaining trademarks in this publication may be trademarks whose use by third parties for their own purposes could violate the rights of the owner.

Disclaimer of Liability

We have reviewed the contents of this publication to ensure consistency with the hardware and software described. Since variance cannot be precluded entirely, we cannot guarantee full consistency. However, the information in this publication is reviewed regularly and any necessary corrections are included in subsequent editions.

Table of contents

1	Introduction.....	7
1.1	Components of the product	7
1.2	Latest information	8
1.3	Technical Support.....	8
1.4	Open Source Software.....	8
1.5	Security information	9
1.6	General safety notes.....	10
1.7	Protective mechanisms against manipulation	11
2	Description.....	13
2.1	Features.....	13
2.2	Measuring inputs.....	17
2.3	Average values and counters	21
2.3.1	Averaging measured values	21
2.3.2	Acquisition of power demand.....	22
2.3.3	Energy counters.....	22
2.3.4	History of active energy consumption.....	23
2.3.5	Configurable universal counter	23
2.3.6	Operating hours counter	23
2.3.7	Limits.....	23
2.4	Digital inputs and outputs	26
2.4.1	Digital inputs	26
2.4.2	Digital outputs	27
2.5	RS485 interface PAC3120 and PAC3220 only	29
2.6	Ethernet interface (PAC3220 only)	30
2.7	Slots for expansion modules.....	32
3	Mounting.....	35
3.1	Mounting on the switching panel	37
3.2	Deinstallation	38
4	Connection	39
4.1	Safety instructions.....	39
4.2	Connections	42
4.3	Connection examples	46
4.4	Connecting to the RS485 bus (PAC3120 only)	53

5	Commissioning	55
5.1	Overview	55
5.2	Applying supply voltage	56
5.3	Parameterizing the device	56
5.3.1	Basic parameters	57
5.3.2	Additional settings	58
5.4	Applying the measuring voltage	58
5.5	Applying the measuring current	59
5.6	Checking the displayed measured values	60
6	Operator control.....	61
6.1	Device interface	61
6.1.1	Displays and operator controls	61
6.1.2	Special display elements	62
6.1.3	LED	63
6.1.4	Menu navigation.....	65
6.1.4.1	Measured value level	65
6.1.4.2	Main menu level.....	66
6.1.4.3	Setting level.....	66
6.1.4.4	Editing level.....	66
6.1.5	Control keys	67
7	Parameter assignment.....	69
7.1	Introduction	69
7.2	Parameterizing via the operator interface.....	70
7.2.1	Device information	71
7.2.2	Language	71
7.2.3	Basic parameters	72
7.2.4	Date/time.....	73
7.2.5	Integrated I/Os	75
7.2.6	Communication	80
7.2.7	Display	82
7.2.8	Advanced	83
7.2.8.1	Password	83
7.2.8.2	Write protection	84
7.2.8.3	Resetting	86
8	Security features.....	87
8.1	Password protection	87
8.2	Hardware write protection	89
8.3	Device access control (IP filter) (PAC3220 only).....	90
8.4	Configuring the Modbus TCP port (PAC3220 only).....	91

9	Service and maintenance	93
9.1	Cleaning.....	93
9.2	Firmware update.....	93
9.3	Warranty.....	94
10	Technical data	95
10.1	Technical data.....	95
10.2	Labeling.....	106
11	Dimensional drawings	109
A	Appendix	111
A.1	Modbus.....	111
A.1.1	Function codes.....	111
A.1.2	Exception codes.....	112
A.1.3	Modbus measured variables with the function codes 0x03 and 0x04.....	113
A.1.4	Structure - Digital input status and digital output status with the function codes 0x03 and 0x04.....	119
A.1.5	Structure - Device diagnostics and device status with the function codes 0x03 and 0x04.....	120
A.1.6	Modbus status parameters with the function code 0x02.....	121
A.1.7	Modbus settings with the function codes 0x03, 0x04 and 0x10.....	123
A.1.8	Modbus communication parameters with the function codes 0x03, 0x04 and 0x10.....	136
A.1.9	Modbus command parameters.....	138
A.1.10	MODBUS standard device identification with the function code 0x2B.....	139
A.1.11	Demand value measured variables with Modbus function code 0x14.....	140
A.1.12	Active energy history with Modbus function code 0x14.....	147
	Index	155

Introduction

1.1 Components of the product

Scope of supply of PAC3120

The PAC3120 package includes:

- One PAC3120 power monitoring device
- Two brackets for panel mounting
- A set of operating instructions for the PAC3120

Scope of supply of PAC3220

The PAC3220 package includes:

- One PAC3220 power monitoring device
- Two brackets for panel mounting
- A set of operating instructions for the PAC3220

Available software

- SENTRON powerconfig software
(<https://support.industry.siemens.com/cs/ww/en/view/63452759>)
- SENTRON powermanager software
(<https://support.industry.siemens.com/cs/document/64850998>)

Available accessories

- Compact bracket (7KM9900-0GA00-0AA0)

Accessories available only for the PAC3220

- 7KM PROFIBUS DP expansion module
(7KM9300-0AB00-0AA0; 7KM9300-0AB01-0AA0)
- 7KM RS485 expansion module
(7KM9300-0AM00-0AA0)
- 7KM 4DI/2DO expansion module
(7KM9200-0AB00-0AA0)

1.2 Latest information

- 7KM I(N), I(Diff) expansion module, analog (7KM9200-0AD00-0AA0)
- 7KM Switched Ethernet PROFINET expansion module (7KM9300-0AE02-0AA0)

1.2 Latest information

Up-to-the-minute information

You can find further support on the Internet (<http://www.siemens.com/lowvoltage/technical-assistance>).

1.3 Technical Support

You can find further support on the Internet at:

Technical Support (<http://www.siemens.com/lowvoltage/technical-support>)

1.4 Open Source Software

This product, solution or service ("Product") contains third-party software components. These components are Open Source Software licensed under a license approved by the Open Source Initiative (www.opensource.org) (<http://www.opensource.org>) or similar licenses as determined by SIEMENS ("OSS") and/or commercial or freeware software components. With respect to the OSS components, the applicable OSS license conditions prevail over any other terms and conditions covering the Product. The OSS portions of this Product are provided royalty-free and can be used at no charge.

If SIEMENS has combined or linked certain components of the Product with/to OSS components licensed under the GNU LGPL version 2 or later as per the definition of the applicable license, and if use of the corresponding object file is not unrestricted ("LGPL Licensed Module", whereas the LGPL Licensed Module and the components that the LGPL Licensed Module is combined with or linked to is the "Combined Product"), the following additional rights apply, if the relevant LGPL license criteria are met: (i) you are entitled to modify the Combined Product for your own use, including but not limited to the right to modify the Combined Product to relink modified versions of the LGPL Licensed Module, and (ii) you may reverse-engineer the Combined Product, but only to debug your modifications. The modification right does not include the right to distribute such modifications and you shall maintain in confidence any information resulting from such reverse-engineering of a Combined Product.

Certain OSS licenses require SIEMENS to make source code available, for example, the GNU General Public License, the GNU Lesser General Public License and the Mozilla Public License. If such licenses are applicable and this Product is not shipped with the required source code, a copy of this source code can be obtained by anyone in receipt of this

information during the period required by the applicable OSS licenses by contacting the following address:

Siemens AG
Smart Infrastructure
Low Voltage Products
Technical Support
Postfach 10 09 53
93009 Regensburg
Germany

www.siemens.com/lowvoltage/support-request
(<https://support.industry.siemens.com/cs/us/en/ps>)

Keyword: Open Source Request (please specify Product name and version, if applicable)

SIEMENS may charge a handling fee of up to 5 EUR to fulfil the request.

Warranty regarding further use of the Open Source Software

SIEMENS' warranty obligations are set forth in your agreement with SIEMENS. SIEMENS does not provide any warranty or technical support for this Product or any OSS components contained in it if they are modified or used in any manner not specified by SIEMENS. The license conditions may contain disclaimers that apply between you and the respective licensor. For the avoidance of doubt, SIEMENS does not make any warranty commitment on behalf of or binding upon any third-party licensor. The Open Source Software used in the product and the license agreements concerning this software can be found in the Readme_OSS.

1.5 Security information

Siemens provides products and solutions with industrial security functions that support the secure operation of plants, systems, machines and networks.

In order to protect plants, systems, machines and networks against cyber threats, it is necessary to implement – and continuously maintain – a holistic, state-of-the-art industrial security concept. Siemens' products and solutions constitute one element of such a concept.

Customers are responsible for preventing unauthorized access to their plants, systems, machines and networks. Such systems, machines and components should only be connected to an enterprise network or the Internet if and to the extent such a connection is necessary and only when appropriate security measures (e.g. firewalls and/or network segmentation) are in place.

For additional information on industrial security measures that may be implemented, please visit (<https://www.siemens.com/industrialsecurity>).

Siemens' products and solutions undergo continuous development to make them more secure. Siemens strongly recommends that product updates are applied as soon as they are available and that the latest product versions are used. Use of product versions that are no longer supported, and failure to apply the latest updates may increase customer's exposure to cyber threats.

To keep up to date with all the latest product updates, subscribe to the Siemens Industrial Security RSS Feed at (<https://www.siemens.com/industrialsecurity>).

1.6 General safety notes



! DANGER

Hazardous voltage.
Will cause death, serious personal injury, or equipment damage.

Turn off and lock out all power supplying this equipment before working on this device.



! WARNING

Impairment of protection as a result of improper use.
Unsuitable or improper use and opening or manipulating the device may cause death, serious personal injury, equipment damage or device failure.

The effectiveness of the protective systems integrated in the device may be undermined if it is not used in the proper way.

The device may be used only for the applications described in the catalog and the associated technical documentation.

Note

These operating instructions do not purport to cover all details or variations in equipment, or to provide for every possible contingency in connection with installation, operation, or maintenance. Should additional information be desired, or should particular problems arise that are not discussed in enough detail in the operating instructions, please contact Technical Support (<https://www.siemens.com/lowvoltage/technical-support>) for the information you require.

Safety-related symbols on the device

	Symbol	Meaning
(1)		Risk of electric shock
(2)		General warning symbol
(3)		Electrical installation and maintenance by qualified personnel only

See also

Applying supply voltage (Page 56)

Applying the measuring voltage (Page 58)

Applying the measuring current (Page 59)

1.7 Protective mechanisms against manipulation

Note**Risk of manipulation**

Several protective mechanisms can be activated in the device.

In order to reduce the risk of manipulation occurring on the device, it is recommended that the protective mechanisms available in the device are activated:

- Password protection, to protect device against unintentional adjustment of parameters.
 - Hardware write protection, to effectively prevent changes to the device parameters without physical access to the device.
-

For further information, please refer to chapter Parameterizing via the operator interface (Page 70).

1.7 Protective mechanisms against manipulation

Description

2.1 Features

Area of application

These are power monitoring devices for measuring the basic electrical variables in low-voltage power distribution. They are capable of single-phase, two-phase, or three-phase measurement and can be used in two, three or four-wire TN, TT, and IT systems.

The power monitoring devices are designed for panel mounting. It is also possible to mount them on a standard rail using the standard rail support brackets available as an option.

The power monitoring devices are suitable for installation in residential and industrial environments.

Thanks to their large measuring voltage range, the devices can be directly connected in any low-voltage system up to a rated voltage U_{L-N} of 400 V. They can also be employed in conjunction with voltage transformers to take measurements in medium- or high-voltage systems.

$x / 1$ A or $x / 5$ A current transformers can be used to measure current.

The power monitoring devices have a large, graphical LC display on which all measured variables are clearly visible. The four function keys combined with the multi-language plaintext displays make intuitive user guidance possible. The experienced operator can also use direct navigation for quicker selection of the desired display menu.

The power monitoring devices have a range of useful monitoring, diagnostics and service functions, a two-tariff active energy and reactive energy counter, a universal counter, and an operating hours counter for monitoring the running time of connected loads.

PAC3120

The PAC3120 can be configured via the integrated RS485 interface. Measured data can be exported for further processing.

The PAC3120 features:

- Two digital inputs
- Two digital outputs

The parameters can be set either directly on the power monitoring device or via powerconfig via the RS485 interface.

PAC3220

The PAC3220 has two identical Ethernet interfaces with integral switch. These can be used to connect other Ethernet nodes to the network.

Two identical expansion module interfaces allow the connection of a further two optionally available expansion modules. Expansion modules can be used to connect the power monitoring device to another bus system or to expand its range of functions.

The PAC3220 features:

- Two digital inputs
- Two digital outputs

An optional expansion module can be installed to increase the available number of inputs and outputs.

The parameters can be set either directly on the power monitoring device or via the communication interface.

Measurement

- Measurement of all relevant electrical variables in an AC system
- Measurement of minimum and maximum values of all measured variables
- Averaging of all measured values directly on the device in two stages, which are independent of each other and freely configurable (aggregation)

Counters and power demand

- A number of energy counters capture active energy, reactive energy, apparent energy for off-peak and on-peak, import and export.
- Calculation and storage of the average value for active power and reactive power from the last demand period to allow simple generation of load profiles using software. Programmable demand period from 1 to 60 mins.
- Daily energy counter for active energy for each day of the preceding two months.
- Monthly energy counter for active energy for each month of the preceding two years.
- Configurable universal counter for counting limit violations and status changes at the digital input or output, or for indicating the active energy or reactive energy of a connected pulse encoder.
- Operating hours counter for monitoring the runtime of a connected load.

Display and operator control

- LC display
- Four control keys with variable function assignment
- LED with variable function assignment

Software support

- SENTRON powerconfig, version 3.13 or higher
- SENTRON powermanager, version 3.6 or higher

Interfaces

PAC3120

- RS485 interface
- Two multifunctional integral passive digital inputs
- Two multifunctional integral digital outputs

PAC3220

- Two identical Ethernet interfaces
- Two multifunctional integral digital inputs
- Two multifunctional integral digital outputs
- Two slots for operating optional expansion modules¹⁾
- RS485 (when a 7KM RS485 expansion module is used)
- PROFIBUS (when a 7KM PROFIBUS DP expansion module is used)
- Two optional modules, each with four active digital inputs and two digital outputs (when 4DI/2DO expansion modules are used)

¹⁾ The SENTRON PAC3220 supports two expansion modules. One of these may be a communication module (e.g. 7KM Switched Ethernet PROFINET, 7KM PROFIBUS DP or 7KM RS485).

Memory

- Device parameter settings are permanently stored in the device memory.
- Extreme values (maximum or minimum) are permanently stored in the internal device memory.

Values can be reset via SENTRON powerconfig, Modbus command or directly on the device via the menu.

Behavior in the case of power failure and power restore

After a power failure, the device starts back at zero with the calculation of the power demand of the total active power and total reactive power.

Security

- Hardware write protection
- Password protection
- Device access control (IP filter) (PAC3220 only)
- Configurable Modbus TCP port (PAC3220 only)
- DHCP protocol included (PAC3220 only)
- SNTP protocol included (PAC3220 only)
- Lead seals can be attached

Using "Password protection" and "Hardware write protection", you can protect against write access to the device settings. The protection takes effect in case of the following actions:

- Modify parameters in device
- Reset maximum
- Reset minimum
- Reset counter
- Reset device
- Reset device to factory defaults
- Reset password
- Update firmware on device

The data can be read without any restrictions.

Note

Activation of the hardware write protection

When the power monitoring device is connected to a network, it is recommended that the hardware write protection is activated.

2.2 Measuring inputs

Current measurement

NOTICE
AC current measurement only
The devices are not suitable for measuring direct current.

The devices are designed for:

- **Measuring current of 1 A or 5 A for connecting standard current transformers.** Each current measuring input can take a continuous load of 10 A. Surge withstand capability is possible for currents up to 100 A and a duration of 1 s.

Voltage measurement

NOTICE
AC voltage measurement only
The devices are not suitable for measuring DC voltage.

The devices are designed for:

- **Direct measurement on the system or using voltage transformers.** The measuring voltage inputs of the devices measure directly via protective impedances. External voltage transformers are required to measure higher voltages than the permissible rated input voltages.
- **Measuring voltage up to 400 V (347 V for UL)** for all devices.

Connection types

Five connection types have been provided for connecting the devices in two-wire, three-wire or four-wire systems with balanced or unbalanced load.

Table 2- 1 Available connection types

Short code	Connection type
3P4W	3 phases, 4 conductors
3P3W	3 phases, 3 conductors
3P4WB	3 phases, 4 conductors, balanced load
3P3WB	3 phases, 3 conductors, balanced load
1P2W	Single-phase AC

The input circuit of the device must correspond to one of the connection types listed. Select the suitable connection type for the purpose.

Connection examples can be found in chapter Connection (Page 39).

NOTICE

The wrong system connection can cause irreparable damage to the devices.

Before connecting the device, make sure that the local power supply conditions match the specifications on the rating plate.

The short code of the connection type must be entered in the device settings at startup. You can find the instructions for parameterizing the connection type in chapter Commissioning (Page 55).

Displaying the measured variables depending on the connection type

The table below shows which measured values can be represented depending on the connection type.

Table 2- 2 Display of measured variables depending on the connection type

Measured variable	Connection type				
	3P4W	3P3W	3P4WB	3P3WB	1P2W
Voltage L1	✓	-	✓	-	✓
Voltage L2	✓	-	-	-	-
Voltage L3	✓	-	-	-	-
Voltage L1-L2	✓	✓	-	✓	-
Voltage L2-L3	✓	✓	-	✓	-
Voltage L3-L1	✓	✓	-	✓	-
Current L1	✓	✓	✓	✓	✓
Current L2	✓	✓	-	✓	-
Current L3	✓	✓	-	✓	-
Apparent power L1	✓	-	✓	-	✓
Apparent power L2	✓	-	-	-	-
Apparent power L3	✓	-	-	-	-
Total apparent power	✓	✓	✓	✓	✓
Active power L1	✓	-	✓	-	✓
Active power L2	✓	-	-	-	-
Active power L3	✓	-	-	-	-
Total active power	✓	✓	✓	✓	✓
Reactive power L1 (VAR1)	✓	-	✓	-	✓
Reactive power L2 (VAR1)	✓	-	-	-	-
Reactive power L3 (VAR1)	✓	-	-	-	-
Total reactive power (VAR1)	✓	✓	✓	✓	✓
Power factor PF L1	✓	-	✓	-	✓
Power factor PF L2	✓	-	-	-	-
Power factor PF L3	✓	-	-	-	-

Measured variable	Connection type				
	3P4W	3P3W	3P4WB	3P3WB	1P2W
Total power factor PF	✓	-	-	-	-
Cos ϕ L1	✓	✓	✓	✓	-
Cos ϕ L2	✓	✓	-	-	✓
Cos ϕ L3	✓	✓	-	-	-
Total cos ϕ	✓	✓	-	-	-
Frequency	✓	✓	✓	✓	✓
Unbal. voltage	✓	✓	✓	✓	-
Unbal. current	✓	✓	✓	✓	-
THD current L1	✓	✓	✓	✓	✓
THD current L2	✓	✓	-	-	-
THD current L3	✓	✓	-	-	-
THD voltage L1	✓	-	✓	-	✓
THD voltage L2	✓	-	-	-	-
THD voltage L3	✓	-	-	-	-
THD voltage L1-L2	✓	✓	-	✓	-
THD voltage L2-L3	✓	✓	-	-	-
THD voltage L3-L1	✓	✓	-	-	-
Total apparent energy T1	✓	✓	✓	✓	✓
Total apparent energy T2	✓	✓	✓	✓	✓
Apparent energy T1 (L1)	✓	-	-	-	✓
Apparent energy T2 (L1)	✓	-	-	-	✓
Apparent energy T1 (L2)	✓	-	-	-	-
Apparent energy T2 (L2)	✓	-	-	-	-
Apparent energy T1 (L3)	✓	-	-	-	-
Apparent energy T2 (L3)	✓	-	-	-	-
Total apparent energy T1+T2	✓	✓	✓	✓	✓
Total apparent energy T1+T2 (secondary)	✓	✓	✓	✓	✓
Total active energy import T1	✓	✓	✓	✓	✓
Total active energy import T2	✓	✓	✓	✓	✓
Active energy import T1 (L1)	✓	-	-	-	✓
Active energy import T2 (L1)	✓	-	-	-	-
Active energy import T1 (L2)	✓	-	-	-	-
Active energy import T2 (L2)	✓	-	-	-	-
Active energy import T1 (L3)	✓	-	-	-	-
Active energy import T2 (L3)	✓	-	-	-	-
Total active energy export T1	✓	✓	✓	✓	✓
Total active energy export T2	✓	✓	✓	✓	✓
Active energy export T1 (L1)	✓	✓	✓	✓	✓
Active energy export T2 (L1)	✓	✓	✓	✓	✓
Active energy export T1 (L2)	✓	✓	✓	✓	✓
Active energy export T2 (L2)	✓	✓	✓	✓	✓

Description

2.2 Measuring inputs

Measured variable	Connection type				
	3P4W	3P3W	3P4WB	3P3WB	1P2W
Active energy export T1 (L3)	✓	✓	✓	✓	✓
Active energy export T2 (L3)	✓	✓	✓	✓	✓
Total active energy import T1+T2	✓	✓	✓	✓	✓
Total active energy export T1+T2	✓	✓	✓	✓	✓
Total active energy import T1+T2 (secondary)	✓	✓	✓	✓	✓
Total active energy export T1+T2 (secondary)	✓	✓	✓	✓	✓
Total reactive energy import T1	✓	✓	✓	✓	✓
Total reactive energy import T2	✓	✓	✓	✓	✓
Reactive energy import T1 (L1)	✓	-	-	-	✓
Reactive energy import T2 (L1)	✓	-	-	-	-
Reactive energy import T1 (L2)	✓	-	-	-	-
Reactive energy import T2 (L2)	✓	-	-	-	-
Reactive energy import T1 (L3)	✓	-	-	-	-
Reactive energy import T2 (L3)	✓	-	-	-	-
Total reactive energy export T1	✓	✓	✓	✓	✓
Total reactive energy export T2	✓	✓	✓	✓	✓
Reactive energy export T1 (L1)	✓	✓	✓	✓	✓
Reactive energy export T2 (L1)	✓	✓	✓	✓	✓
Reactive energy export T1 (L2)	✓	✓	✓	✓	✓
Reactive energy export T2 (L2)	✓	✓	✓	✓	✓
Reactive energy export T1 (L3)	✓	✓	✓	✓	✓
Reactive energy export T2 (L3)	✓	✓	✓	✓	✓
Total reactive energy import T1+T2	✓	✓	✓	✓	✓
Total reactive energy export T1+T2	✓	✓	✓	✓	✓
Total reactive energy import T1+T2 (secondary)	✓	✓	✓	✓	✓
Total reactive energy export T1+T2 (secondary)	✓	✓	✓	✓	✓
Universal counter	✓	✓	✓	✓	✓
Operating hours counter	✓	✓	✓	✓	✓

The measured values specified in the table are displayed as instantaneous, minimum and maximum values.

2.3 Average values and counters

2.3.1 Averaging measured values

Based on selected recordings of measured values over time, the user can optimize the system in accordance with requirements (e.g. with respect to energy consumption), and comply with normative requirements relating to power and energy recordings. For this purpose, instantaneous values need to be read out via the communication port, calculated and stored. The uninterrupted recording that is necessary requires a high bandwidth, high availability of communication and high storage capacity.

The power monitoring device generates all the measured values every 200 ms approximately. The device therefore features two internal average value generators which can be parameterized independently of each other. The time averages formed in the device are generated continuously based on all the associated values.

The values are updated after expiry of the set time period in each case.

- The default setting for average value 1 is a period of 10 seconds.
- The default setting for average value 2 is a period of 15 minutes.

The period can be set to anything between 3 seconds and 31536000 seconds (1 year).

The function is available only via communication interfaces.

A list of available measured values can be found in chapter Demand value measured variables with Modbus function code 0x14 (Page 140).

2.3.2 Acquisition of power demand

Values that can be read out

The power monitoring devices supply the power demand of the last completed demand period:

- Average values for active power and reactive power, separated in each case for import and export
- Minimum and maximum within the period
- Length of the demand period in seconds. The period may be shorter due to external synchronization.
- Time in seconds since the last synchronization or since completion of the last period

Note

The power demand can only be read out via the interface (it is not shown on the display).

The average values of the last demand period can only be retrieved during the active demand period.

Example: Period length and length of the demand period
Period length: 15 min; time of day: 13:03; time in seconds: 180 s.

The following can be calculated from this: The last demand period ended at 13:00. The active demand period will end at 13:15 or in 12 min.

Adjustable parameters

- Time interval in minutes: 1 to 60 min adjustable, default 15 min
- Synchronization via bus or digital input

2.3.3 Energy counters

Energy counters

The power monitoring devices have energy counters for recording

- Active energy import
- Active energy export
- Reactive energy import
- Reactive energy export
- Apparent energy

2.3.4 History of active energy consumption

Based on selected recordings of energy consumption over time, users can perform a targeted analysis of their energy consumption for the purpose of optimizing their energy usage. The power monitoring devices have a daily energy counter and a monthly energy counter.

- The daily energy counter records the active energy for each day of the preceding two months.
- The monthly energy counter records the active energy for each month of the preceding two years.

This function is available only in conjunction with communication interfaces. A list of available measured values can be found in chapter Active energy history with Modbus function code 0x14 (Page 147).

2.3.5 Configurable universal counter

The devices provide one configurable counter. The following counting options are available:

- Pulse counting via the digital input for kWh/kvarh
- Status changes at the digital input (rising edge only)
- Status changes at the digital output (rising edge only)
- Limit violations

2.3.6 Operating hours counter

The operating hours counter is used for monitoring the runtime of a connected load (only functions when energy counting is implemented).

2.3.7 Limits

The power monitoring devices have a function for monitoring up to six limit values. These can be monitored for violation of the upper or lower limit. If a limit value is violated, specific actions can be triggered.

In addition, the limit values can be combined with each other using a logic operation. The result of the logic operation can also be used to trigger specific actions in the same way as the individual limit values.

The limit violations are shown on the display.

Defining the limit values

The following must be specified for each of the six limit values in order to program the limit monitoring function:

- Limit monitoring on/off
- Monitored measured variable
- Upper or lower limit violated
- Limit
- Time delay
- Hysteresis

Combining the limit values

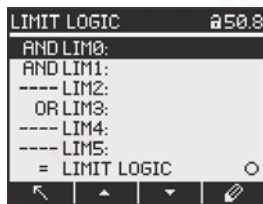

Figure 2-1 Device setting "LIMIT LOGIC"

The following operators are available:

- AND
- OR

The placeholder "----" means: This limit value is not combined with any other limit value.

The logic combines limit values 0 to 5 as follows:

$(((((opLIM0 opLIM1 LIM1) opLIM2 LIM2) opLIM3 LIM3) opLIM4 LIM4) opLIM5 LIM5)$

LIM0 represents limit value 0

LIM1 represents limit value 1

LIMx represents limit value x

op represents the logic operator AND/OR in the formula

The brackets in the formula show that the AND/OR priority rule does not apply.

The result of the logic operation is the "LIMIT LOGIC".

Output of limit violations

- Indication of limit violation on the display:

"MAIN MENU > SETTINGS > ADVANCED > LIMITS > LIMIT LOGIC"

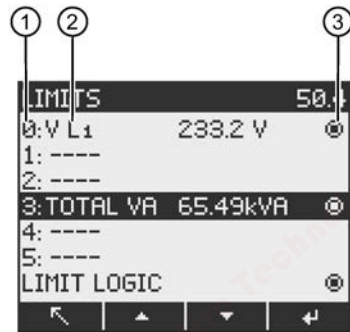

- ① Limit value designation
- ② Monitored data source
- ③ Limit value currently violated (● = yes, ○ = no)

Figure 2-2 Display of limit violation

- Output of the limit violation at the digital output
- Output of limit violations via the interface
- Counting limit violations with the universal counter

2.4 Digital inputs and outputs

The power monitoring device features:

- Two multifunctional digital passive inputs
- Two multifunctional digital outputs

2.4.1 Digital inputs

The following functions can be assigned to the digital inputs:

- Tariff switching for two-tariff active and reactive energy counters
- Synchronization of the demand period by means of the synchronization pulse of a system control center or other device
- Status monitoring: Acquisition of statuses and messages of connected signal encoders
- Energy pulse input for active or reactive energy pulses. Data is transferred with the help of weighted pulses, e.g. a parameterizable number of pulses is transferred for each kWh.

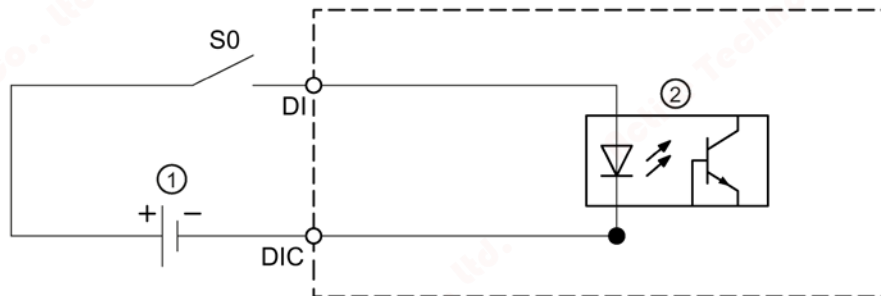

- ① External power supply
- ② Input electronics

Figure 2-3 Block diagram: Digital inputs

Wiring

Switch with external power supply

An external voltage of up to max. 30 V (typically 24 V) must be connected to terminal DIC.

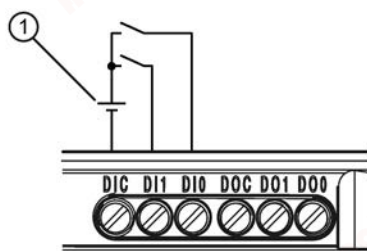

① External voltage

Figure 2-4 Digital inputs with switch and external power supply at terminal DIC

2.4.2 Digital outputs

Functions

The following functions can be assigned to the digital outputs:

- Energy pulse output, programmable for active energy pulses or reactive energy pulses
- Indication of the direction of rotation
- Operating state display of the device
- Signaling of limit violations
- Switching output for remote control via the interface

The following functions can be assigned to both digital outputs:

- Remote control
The digital output is remotely controlled via the integral communication interface. The Modbus function codes can be found in chapter Modbus (Page 111).
- Direction of rotation
The digital output is switched on by a counter-clockwise rotating electrical field and remains active while the direction of rotation of the field remains unchanged.
- Energy pulse
The digital output outputs the parameterized number of pulses per energy unit (e.g. kWh). The specified energy counter is evaluated here.

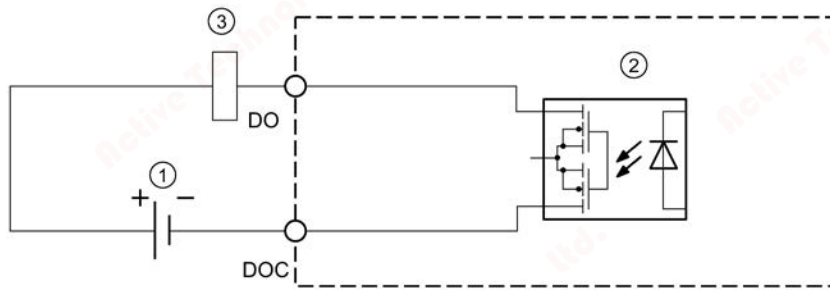

- ① External power supply
- ② Input electronics
- ③ Load

Figure 2-5 Block diagram: Digital outputs

Wiring

Both digital outputs are passive and implemented exclusively as switches.

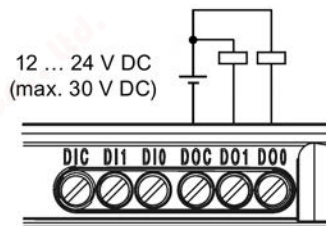
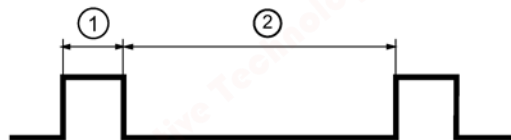

Figure 2-6 Block diagram: Digital outputs

Implementation of the pulse function corresponds to the IEC 62053-31 standard.

Pulse length, turn-off time



- ① Pulse length
- ② Turn-off time

Figure 2-7 Pulse length and turn-off time

- **Pulse length:**
Time for which the signal at the digital output is "high". The minimum pulse length is 30 ms and the maximum 500 ms.
- **Turn-off time:**
Time for which the signal at the digital output is "low". The turn-off time depends on the measured energy, for example, and can be days or months.
- **Minimum turn-off time:**
The minimum turn-off time corresponds to the programmed pulse length. 30 ms is the absolute minimum.

2.5 RS485 interface PAC3120 and PAC3220 only

RS485 interface for Modbus RTU communication

The PAC3120 is equipped with an RS485 interface for Modbus RTU communication. The device operates as a Modbus slave.

Application

This interface permits:

- Reading out the measured values
- Reading and writing the device settings
- Updating the device firmware

The Modbus function codes are listed in the Appendix.

Conditions for operation

To use the interface, the device must be parameterized in accordance with the existing Modbus infrastructure. The communication parameters can be set on the device and via the Modbus RTU interface.

Default communication settings

In the as-delivered state, the following default values are set:

Table 2- 3 Default Modbus RTU communication settings

Setting	Default value
Address	126
Baud rate	19200
Data format	8N2
Response time	0 (automatic)

Delaying the response time

The response time of the PAC3120 may have to be delayed to enable its operation as a slave device with devices from other manufacturers on the bus. The PAC3120 can automatically calculate the response time to suit the baud rate. This automatic calculation is set at the factory. The delay time is individually adjustable between 1 ms and 255 ms.

Polarization

Polarization of the RS485 data lines must be implemented at another point on the bus. The PAC3120 does not contain polarization resistors.

PAC3220 with RS485 expansion module

You can find information about setting parameters in the documentation for the SENTRON PAC RS485 expansion module

(<https://support.industry.siemens.com/cs/ww/en/view/28865965>) under www.modbus.org (<http://www.modbus.org>) in the following specification: Modbus over Serial Line (http://modbus.org/docs/Modbus_over_serial_line_V1_02.pdf).

2.6 Ethernet interface (PAC3220 only)

Protocols

The **Ethernet interface (PAC3220 only)** allows communication via the following protocols:

- Modbus TCP
The device can be configured via Modbus TCP.
- Web server (HTTP)
The protocol can only be used to read out the measured values via web browser.
- SNTP
The SNTP (Simple Network Time Protocol) is used to automatically synchronize the internal clock with a time server within the network. Three function modes are available:
 - No synchronization
 - Date/time synchronization via device request
The IP address of an NTP server must be configured. With this, the SENTRON PAC3220 automatically requests the current time from the server and resets its internal clock, if necessary.
 - Date/time synchronization via SNTP server (BCST)
The PAC3220 receives broadcast time frames which are sent from an NTP server. This is useful if the internal clocks of several devices in the same network need to remain synchronized.
If the IP address of the NTP server has been configured, the PAC3220 only responds to these frames. Furthermore, it can itself send a request to the server if necessary.
- DHCP
DHCP stands for "Dynamic Host Configuration Protocol". Protocol for obtaining network settings from a DHCP server. Network settings are assigned automatically.

Autonegotiation

Autonegotiation is a method used by network communication peers to automatically negotiate the highest possible transmission rate.

The PAC3220 is automatically set to the transmission rate of the communication peer if the latter does not support autonegotiation.

MDI-X auto crossover

MDI-X auto crossover describes the ability of the interface to autonomously detect the send and receive lines of the connected device and adjust to them. This prevents malfunctions resulting from mismatching send and receive lines. Both crossed and uncrossed cables can be used.

2 Port Ethernet Switch

7KM PAC3220 offers 2 Ethernet interfaces that are internally connected via the Ethernet switch.

This means that each Ethernet frame received at one of the ports is forwarded to the other port and, of course, to the PAC3220. This supports Ethernet linear topology for efficient cabling, with no additional cost for external Ethernet switches.

Note

Note for PROFINET

The failure of one of the devices interrupts communication to the devices behind it.

This Ethernet switch is not suitable either in the PROFINET IRT environment or for the ring topology.

The Switched Ethernet PROFINET expansion module (7KM9300-0AE02-0AA0) can be used for both.

2.7 Slots for expansion modules

The PAC3220 has two identical slots (MOD1 and MOD2) for installing optionally available expansion modules.

Please consult the current catalogs to find out which modules are available for the PAC3220.

One expansion module can be operated alone on the device or two expansion modules simultaneously.

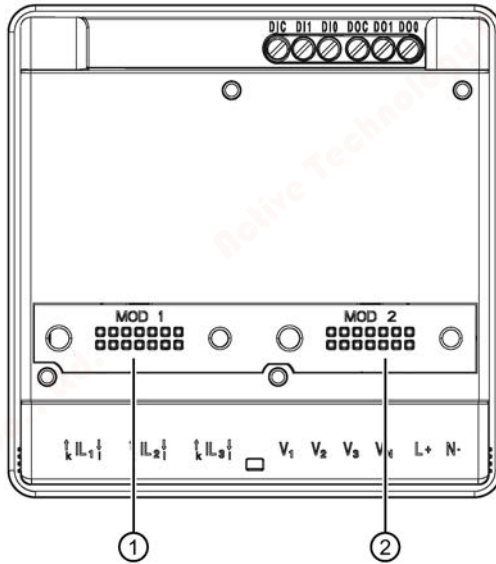

- ① Slot MOD1
- ② Slot MOD2

Figure 2-8 PAC3220, rear of the device

<p>⚠ WARNING</p> <p>Hazardous voltage. May cause death, serious personal injury, or equipment damage.</p> <p>Never insert wires or metal pins into the contact openings of the module interface below the labels "MOD1" and "MOD2", as otherwise hazardous voltages may cause serious personal injury or death. Furthermore, inserting metal pins or wires into the contact openings can cause the device to fail.</p>

NOTICE

Property damage due to contamination

Avoid contamination of the contact areas below the labels "MOD1" and "MOD2", otherwise the expansion modules cannot be inserted and may even sustain damage.
--

You will find further information on the expansion modules in the relevant operating instructions and equipment manuals.

Description

2.7 Slots for expansion modules

Mounting

Mounting location

The devices are intended for installation in permanently installed switching panels within closed rooms.

! WARNING

**Only operate the device in a secure location.
Failure to heed this warning may cause death, serious personal injury, or equipment damage.**

The power monitoring device must always be operated in a lockable control cabinet or a lockable room. Ensure that only qualified personnel have access to this cabinet or room.

Conductive panels and doors on control cabinets must be grounded. The doors of the control cabinet must be connected to the control cabinet using a grounding cable.

Mounting position

The device must be installed vertically.

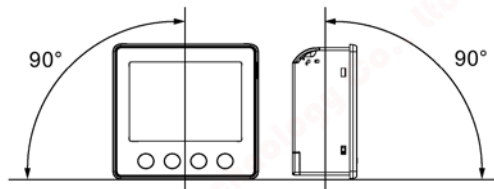

Figure 3-1 Mounting position

Installation space and ventilation

Sufficient clearance must be maintained between the device and neighboring components in order to comply with the permissible operating temperature. You can find dimension specifications in chapter Dimensional drawings (Page 109).

Deploy the power monitoring device only where environmental conditions permit its operation: A description of permissible operating conditions can be found in chapter Technical data (Page 95).

Plan additional space for:

- Ventilation
- Wiring
- Connection of the communication cable and cable infeed on the top of the device

 WARNING
--

<p>The use of a damaged device may result in death, serious physical injury, or property damage.</p>

<p>Do not install or start up damaged devices.</p>
--

Note

Avoid condensation.

Sudden fluctuations in temperature can lead to condensation. Condensation can affect the proper functioning of the device. Store the device in the operating room for at least two hours before commencing installation.

3.1 Mounting on the switching panel

You will require the following tools to install the device:

- Cutting tool for the panel cutout
- PH2 cal. screwdriver acc. to ISO 6789

Additional installation tools

- Cable clamp for strain relief of the communication cable and the connecting cables at the digital inputs/outputs.

Mounting and clearance dimensions

You can find information on the cutout dimensions, frame dimensions and clearances in chapter Dimensional drawings (Page 109).

Installation steps

Proceed as follows to install the power monitoring device in the switching panel:

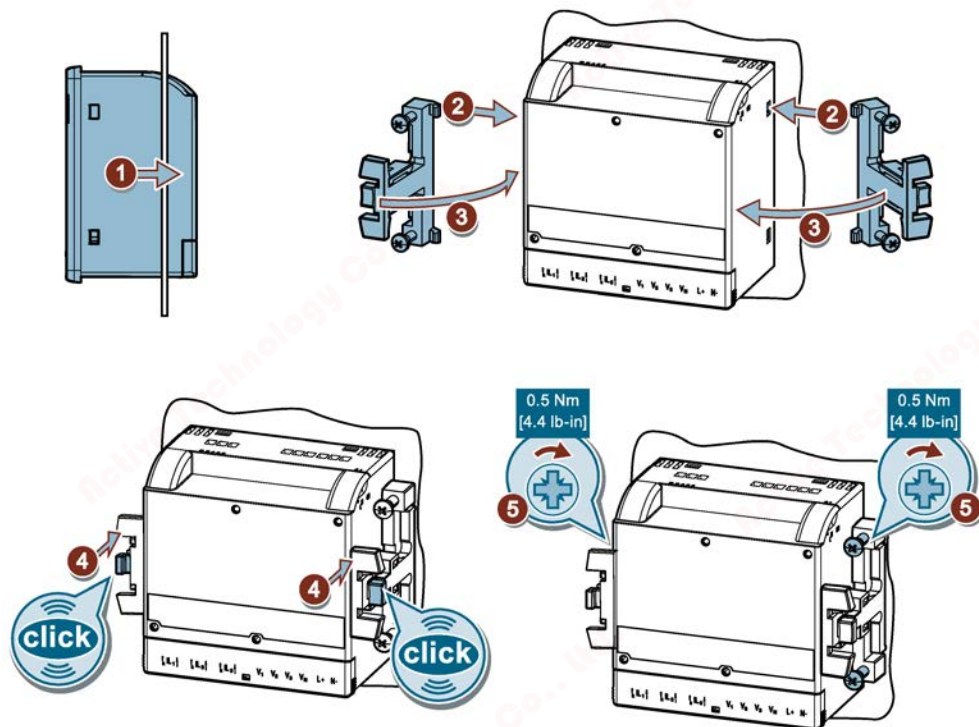

Figure 3-2 Mounting

3.2 Deinstallation

Make sure the device has been shut down before you begin to deinstall it.

Tool

You require the following tools to deinstall the device:

- PH2 screwdriver

Deinstallation steps

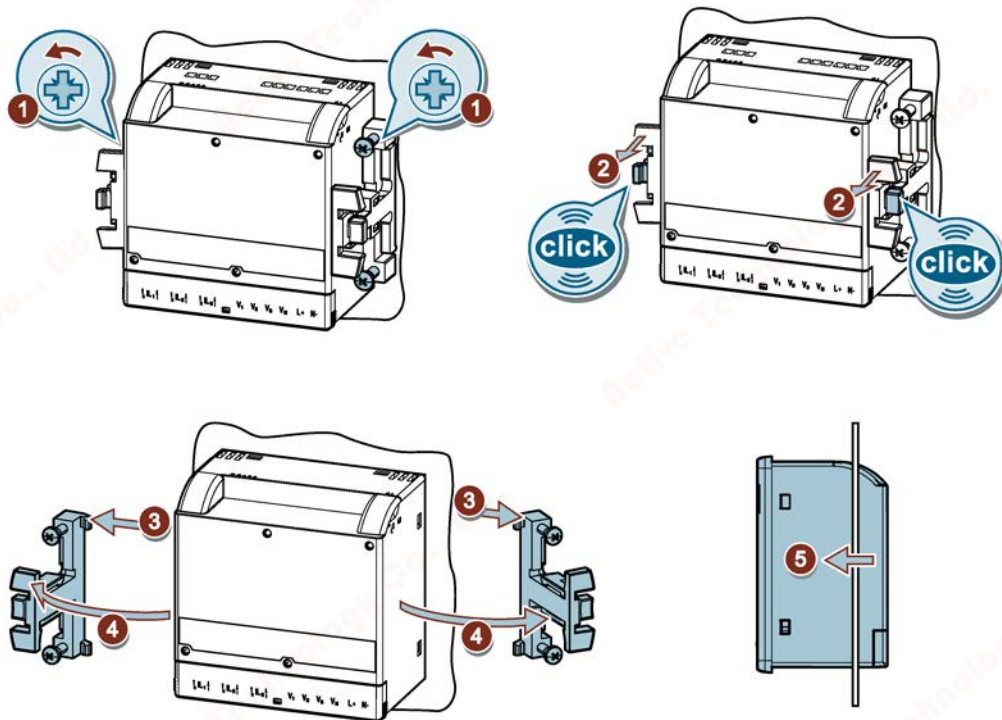

Figure 3-3 Deinstallation

Connection

4.1 Safety instructions

Notes

**! DANGER**

Hazardous voltage.

Will cause death, serious personal injury, or equipment damage.

Turn off and lock out all power supplying this equipment before working on this device.

**! DANGER**

Open transformer circuits will result in electric shock and arc flash hazards.

Will cause death, serious personal injury, or equipment damage.

Do not open the secondary circuit of the current transformers under load. Short circuit the secondary current terminals of the current transformer before removing this device. It is imperative that you follow the safety instructions for the current transformers used.

! CAUTION**Protection of the supply voltage and voltage measuring inputs**

The miniature circuit breakers in the supply voltage and the voltage measuring inputs are only used for cable protection. The method of cable protection must be selected according to the design of the supply cable.

You may use miniature circuit breakers up to 20 A (C). Choose a method of cable protection that conforms to the relevant regulations.

4.1 Safety instructions

 WARNING
Hazardous voltage May cause death, serious personal injury, or equipment damage. <ul style="list-style-type: none">• Always open or disconnect circuit from power-distribution system (or server) of building before installing or servicing current transformers.• The current transformers may not be installed in equipment where they exceed 75 percent of the wiring space of any cross-sectional area within the equipment.• Restrict installation of current transformers in an area where it would block ventilation openings.• Restrict installation of current transformers in an area of breaker arc venting.• Not suitable for Class 2 wiring methods and not intended for connection to Class 2 equipment.• Secure current transformers and route conductors so that they do not directly contact live terminals or bus.

 WARNING
Hazardous voltage. May cause death, serious personal injury, or equipment damage. <p>Never insert wires or metal pins into the contact openings of the module interface below the labels "MOD1" and "MOD2", as otherwise hazardous voltages may cause serious personal injury or death. Furthermore, inserting metal pins or wires into the contact openings can cause the device to fail.</p>

NOTICE
Property damage due to contamination <p>Avoid contamination of the contact areas below the labels "MOD1" and "MOD2", otherwise the expansion modules cannot be inserted and may even sustain damage.</p>

NOTICE
Incorrect line voltage may damage the device. <p>Before connecting the device, make sure that the line voltage matches the specifications on the rating plate.</p>

NOTICE**Short-circuit hazard**

Take the maximum possible ambient temperature into account when selecting the connecting cables.

The cables must be suitable for operation in a temperature that is 20 °C higher than the maximum ambient temperature.

Note

Only qualified personnel are permitted to install, commission or service this device.

- Wear the prescribed protective clothing. Observe the general equipment regulations and safety regulations for working with high-voltage installations (e.g. DIN VDE, NFPA 70E as well as national or international regulations).
- The limits given in the technical data must not be exceeded even during startup or testing of the device.
- The secondary connections of intermediate current transformers must be short-circuited at the transformers before the current feeder cables to the device are interrupted.
- Check the polarity and the phase assignment of the instrument transformers.
- Before connecting the device, make sure that the line voltage matches the specifications on the rating plate.
- Before you start up the device, check that all connections are correct.
- Before power is applied to the device for the first time, it must have been located in the operating area for at least two hours in order to reach temperature balance and avoid humidity and condensation.
- Condensation on the device is not permissible during operation.

Note**Grounding of current transformers optional**

Always connect the transformers and ground them on the secondary side in accordance with the applicable regulations. Grounding of the current transformers on the secondary side is not necessary for use in low-voltage switchboards for performing measuring tasks.

Note**Prevent capacitive and inductive interference**

Make sure that all data and signal cables are routed separately from control and power supply cables. In order to avoid the risk of capacitive or inductive interference, these cables must never be routed in parallel.

4.2 Connections

Connection designations

Connection designations PAC3120

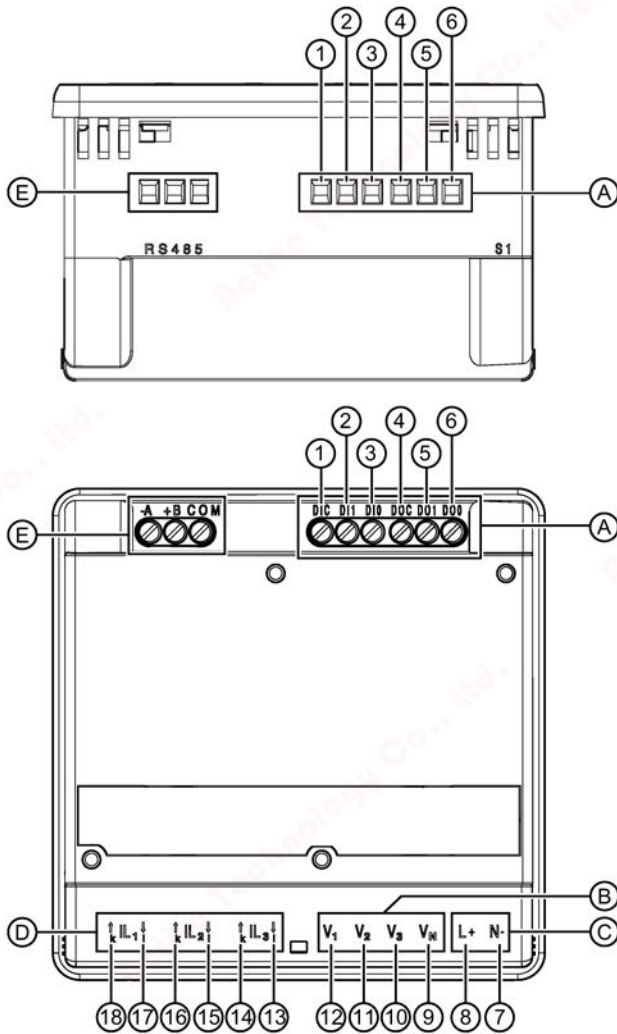

Ⓐ		Digital inputs and outputs
Ⓑ		Measuring inputs voltage V_1, V_2, V_3, V_N
Ⓒ		Supply voltage L/+, N/-
Ⓓ		Measuring inputs current IL_1, IL_2, IL_3
Ⓔ		RS485 connection
①	DIC	Digital input (common)
②	DI1	Digital input 1
③	DI0	Digital input 0
④	DOC	Digital output (common)
⑤	DO1	Digital output 1
⑥	DO0	Digital output 0
⑦	N-	AC: Connection: Neutral conductor DC: Connection: -
⑧	L+	AC: Connection: Conductor (phase voltage) DC: Connection: +
⑨	V_N	Neutral conductor
⑩	V_3	Voltage U_{L3-N}
⑪	V_2	Voltage U_{L2-N}
⑫	V_1	Voltage U_{L1-N}
⑬	IL_3 ↓	I Current I_{L3} , output
⑭	IL_3 ↑ k	k Current I_{L3} , input
⑮	IL_2 ↓	I Current I_{L2} , output
⑯	IL_2 ↑ k	k Current I_{L2} , input
⑰	IL_1 ↓	I Current I_{L1} , output
⑱	IL_1 ↑ k	k Current I_{L1} , input

Figure 4-1 Connection designations on PAC3120 (view from top and rear of the device)

Connection designations PAC3220

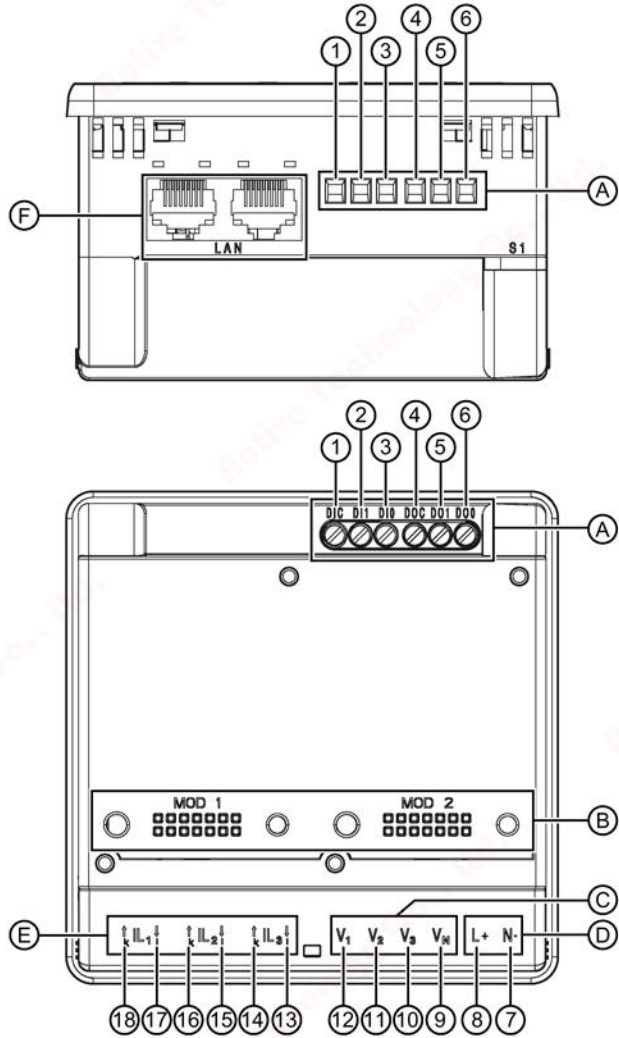

Ⓐ		Digital inputs and outputs
Ⓑ		Slots for expansion modules
Ⓒ		Measuring inputs voltage V_1, V_2, V_3, V_N
Ⓓ		Supply voltage L/+, N/-
Ⓔ		Measuring inputs current IL_1, IL_2, IL_3
Ⓕ		Ethernet interface (two identical connections)
①	DIC	Digital input (common)
②	DI1	Digital input 1
③	DI0	Digital input 0
④	DOC	Digital output (common)
⑤	DO1	Digital output 1
⑥	DO0	Digital output 0
⑦	N-	AC: Connection: Neutral conductor DC: Connection: -
⑧	L+	AC: Connection: Conductor (phase voltage) DC: Connection: +
⑨	V_N	Neutral conductor
⑩	V_3	Voltage U_{L3-N}
⑪	V_2	Voltage U_{L2-N}
⑫	V_1	Voltage U_{L1-N}
⑬	IL_3 ↓	I Current I_{L3} , output
⑭	IL_3 ↑k	k Current I_{L3} , input
⑮	IL_2 ↓	I Current I_{L2} , output
⑯	IL_2 ↑k	k Current I_{L2} , input
⑰	IL_1 ↓	I Current I_{L1} , output
⑱	IL_1 ↑k	k Current I_{L1} , input

Figure 4-2 Connection designations on PAC3220 (view from top and rear of the device)

4.3 Connection examples

The connection examples below show connection in:

- Two, three or four-wire systems
- With balanced or unbalanced load
- With/without voltage transformer

The device can be operated up to the maximum permissible voltage values with or without a voltage measuring transformer.

It is only possible to measure the current with current transformers.

Note

Grounding of current transformers is optional.

The transformers must always be connected and therefore always grounded on the secondary side according to the applicable regulations. Grounding of the current transformers on the secondary side is not necessary for use in low-voltage switchboards for performing measuring tasks.

Example connections

1. **3-phase measurement, 4 conductors, unbalanced load, without voltage transformer, with 3 current transformers**

Connection type 3P4W

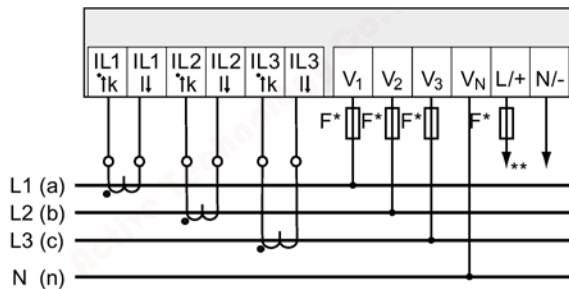

- * The fuses are only used for cable protection. All commercially available miniature circuit breakers up to 20 A (C) can be used.
- ** Connection of supply voltage

Figure 4-3 Connection type 3P4W, without voltage transformer, with three current transformers

2. **3-phase measurement, 4 conductors, unbalanced load, with voltage transformer, with 3 current transformers**

Connection type 3P4W

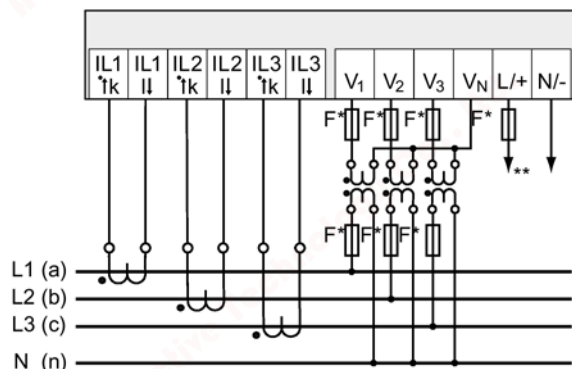

- * The fuses are only used for cable protection.
All commercially available miniature circuit breakers up to 20 A (C) can be used.
- ** Connection of supply voltage

Figure 4-4 Connection type 3P4W, with voltage transformer, with three current transformers

3. **3-phase measurement, 4 conductors, unbalanced load, without voltage transformer, with 1 current transformer**

Connection type 3P4WB

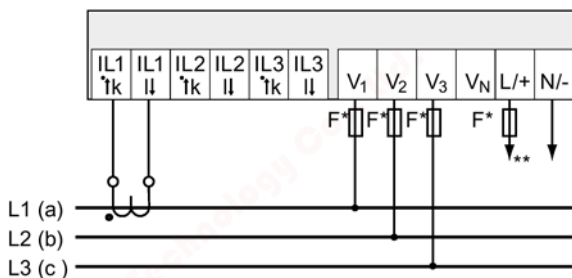

- * The fuses are only used for cable protection.
All commercially available miniature circuit breakers up to 20 A (C) can be used.
- ** Connection of supply voltage

Figure 4-5 Connection type 3P4WB, without voltage transformer, with 1 current transformer

4.3 Connection examples

4. 3-phase measurement, 4 conductors, balanced load, with voltage transformer, with 1 current transformer

Connection type 3P4WB

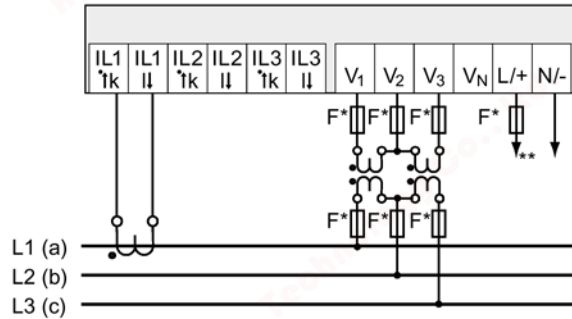

- * The fuses are only used for cable protection. All commercially available miniature circuit breakers up to 20 A (C) can be used.
- ** Connection of supply voltage

Figure 4-6 Connection type 3P4WB, with voltage transformer, with 1 current transformer

5. 3-phase measurement, 3 conductors, unbalanced load, without voltage transformer, with 3 current transformers

Connection type 3P3W

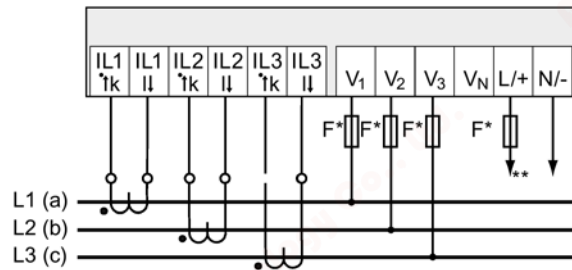

- * The fuses are only used for cable protection. All commercially available miniature circuit breakers up to 20 A (C) can be used.
- ** Connection of supply voltage

Figure 4-7 Connection type 3P3W, without voltage transformer, with 3 current transformers

6. **3-phase measurement, 3 conductors, unbalanced load, with voltage transformer, with 3 current transformers**

Connection type 3P3W

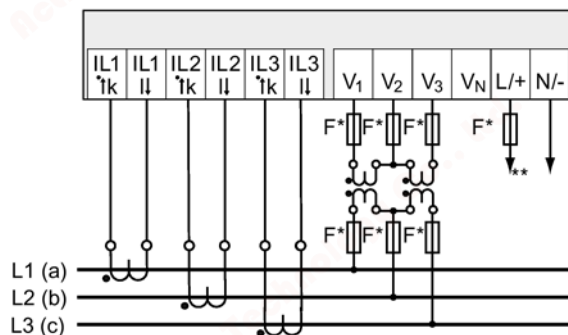

- * The fuses are only used for cable protection.
All commercially available miniature circuit breakers up to 20 A (C) can be used.
- ** Connection of supply voltage

Figure 4-8 Connection type 3P3W, with voltage transformer, with 3 current transformers

7. **3-phase measurement, 3 conductors, unbalanced load, without voltage transformer, with 2 current transformers**

Connection type 3P3W

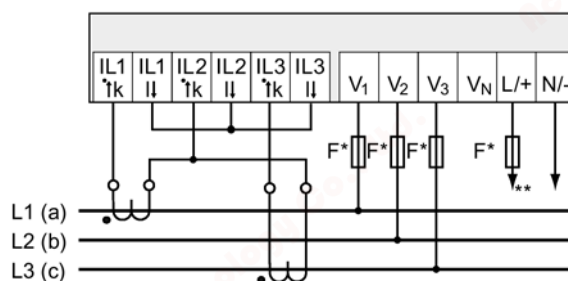

- * The fuses are only used for cable protection.
All commercially available miniature circuit breakers up to 20 A (C) can be used.
- ** Connection of supply voltage

Figure 4-9 Connection type 3P3W, without voltage transformer, with 2 current transformers

4.3 Connection examples

8. 3-phase measurement, 3 conductors, unbalanced load, with voltage transformer, with 2 current transformers

Connection type 3P3W

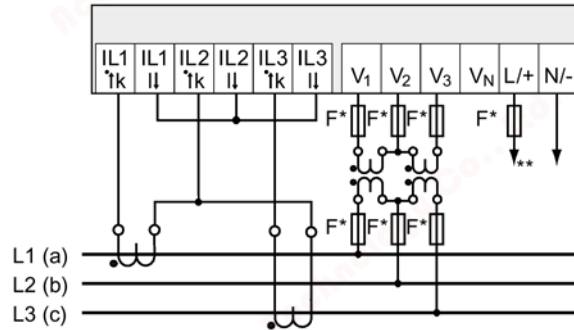

- * The fuses are only used for cable protection.
All commercially available miniature circuit breakers up to 20 A (C) can be used.
- ** Connection of supply voltage

Figure 4-10 Connection type 3P3W, with voltage transformer, with 2 current transformers

9. 3-phase measurement, 3 conductors, balanced load, without voltage transformer, with 1 current transformer

Connection type 3P3WB

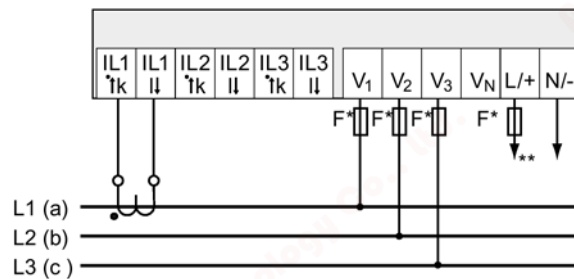

- * The fuses are only used for cable protection.
All commercially available miniature circuit breakers up to 20 A (C) can be used.
- ** Connection of supply voltage

Figure 4-11 Connection type 3P3WB, without voltage transformer, with 1 current transformer

10.3-phase measurement, 3 conductors, balanced load, with voltage transformer, with 1 current transformer

Connection type 3P3WB

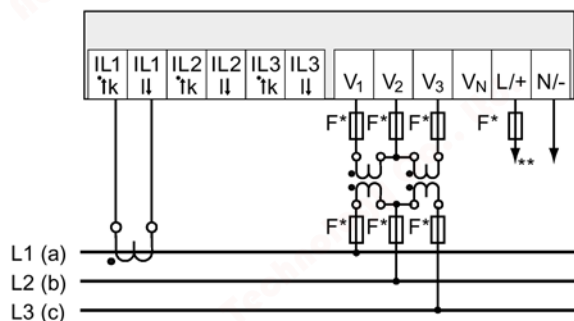

- * The fuses are only used for cable protection.
All commercially available miniature circuit breakers up to 20 A (C) can be used.
- ** Connection of supply voltage

Figure 4-12 Connection type 3P3WB, with voltage transformer, with 1 current transformer

11.2-phase measurement, 3 conductors, unbalanced load, without voltage transformer, with 2 current transformers

Connection type 3P4W

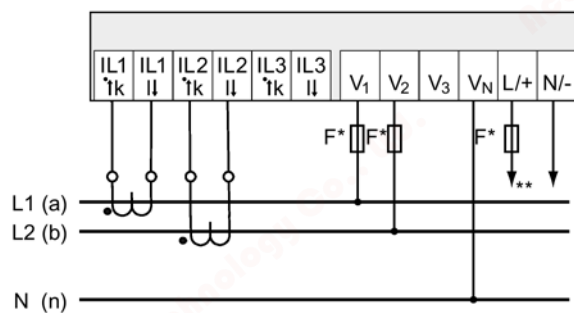

- * The fuses are only used for cable protection.
All commercially available miniature circuit breakers up to 20 A (C) can be used.
- ** Connection of supply voltage

Figure 4-13 Connection type 3P4W, without voltage transformer, with 2 current transformers

12.1-phase measurement, 2 conductors, without voltage transformer, with 1 current transformer

Connection type 1P2W

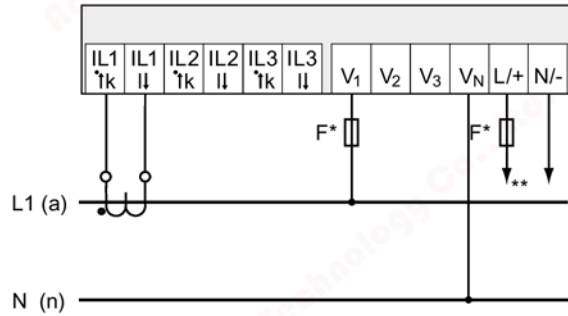

- * The fuses are only used for cable protection.
All commercially available miniature circuit breakers up to 20 A (C) can be used.
- ** Connection of supply voltage

Figure 4-14 Connection type 1P2W, without voltage transformer, with 1 current transformer

See also

Measuring inputs (Page 17)

4.4 Connecting to the RS485 bus (PAC3120 only)

Procedure

Connect the PAC3120 to the RS485 bus via the integral interface. Please pay attention here to the general topology of the two-wire line.

1. Connect all three lines to the screw terminals.
2. Ensure a bus terminating resistance is set at the first and last communication node.

Block diagram

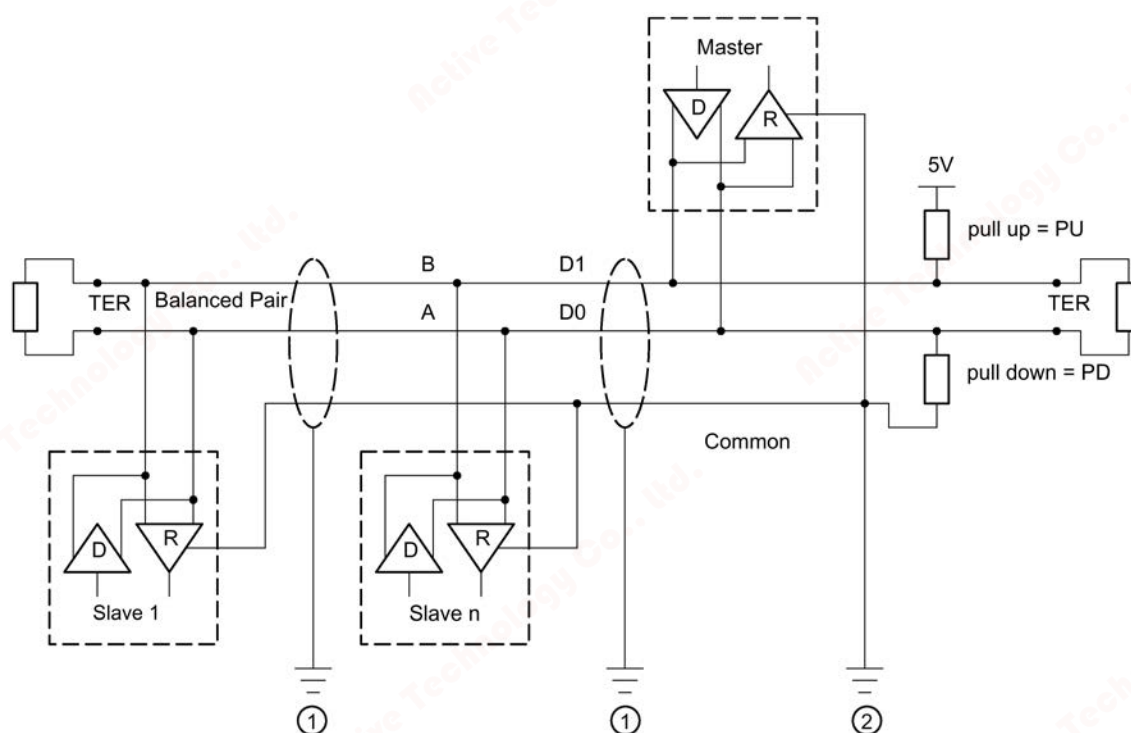

- TER Bus termination resistor (termination)
- PU Pull-up resistor
- PD Pull-down resistor
- ① Grounding of the cable shield
- ② Grounding of the common line, preferably only at one point for the whole bus

Figure 4-15 Block diagram: General RS485 topology

4.4 Connecting to the RS485 bus (PAC3120 only)

Grounding the cable shield

The serial Modbus data line must be shielded. The shield must be connected to protective ground at one end of the line at least. Strive to achieve grounding of the shield on both sides.

Grounding the common line

The common line must be applied direct to protective ground, preferably at only one point for the whole bus. It must be ensured that the common signal is routed as a dedicated line.

Polarization

The PAC3120 does not support polarization of the RS485 data lines. Polarization must be implemented at another point on the bus. The master device usually performs the polarization.

We recommend polarization with supply of 5 V DC, pull-up resistor with 560 Ω , pull-down resistor with 560 Ω .

Bus terminator

The first and last node in the bus segment must terminate the bus with a terminating resistor.

The PAC3120 does not support bus termination. The bus can be terminated using an external resistor $\geq 120 \Omega$. Connect the resistor to terminals -/A and +/B of the RS485.

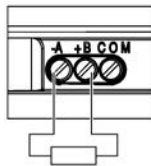

Figure 4-16 Bus termination using external resistor

References

You can find further information in the following specification and the guidelines on the website of the Modbus Organization (<https://www.modbus.org>).

Commissioning

5.1 Overview

Prerequisites

1. The device has been installed.
2. The device has been connected in accordance with the possible connection methods.
3. PAC3120: The RS485 interface has been connected to the bus.
PAC3220: The Ethernet cable has been connected.
Note: Optional for commissioning with powerconfig.

Steps for starting up the device

1. Connect the supply voltage.
2. Parameterize the device.
3. Connect the measuring voltage.
4. Connect the measuring current.
5. Check the displayed measured values.
6. Check the polarity and the phase assignment of the instrument transformers.

Note

Check the connections

Incorrect connection can result in malfunctions and failure of the device.

Before starting up the power monitoring device, check that all connections are correct.

5.2 Applying supply voltage

The measuring device can be supplied with:

- a wide-voltage AC/DC power supply unit
- an extra-low voltage DC power supply unit

A supply voltage is required to operate the device. Please consult the technical data or the rating plate for the type and level of the possible supply voltage.

NOTICE
The wrong system connection can destroy the device.
Failure to heed this warning can result in damage to the device and the system. The minimum and maximum limits given in the technical data and on the rating plate must not be exceeded even during startup or testing of the device.
Observe the correct polarity when connecting DC supply voltage.

5.3 Parameterizing the device

To start up the device, you must specify the operating parameters listed below in the device settings:

- Basic parameters

The following settings are also useful:

- Language
- Date/time
- Device protection against manipulation

Initial startup



The language selection only appears:

- During initial startup
- After a reset to factory settings
- After a firmware update

Select the required language and confirm your selection by choosing "OK".

5.3.1 Basic parameters

Set the basic parameters:

- Connection type
 - Direct measurement on the system or using voltage transformers
 - Measuring input voltage in the case of direct measurement on the system
 - Primary and secondary voltage in the case of measurement using voltage transformers
- Current
 - Primary current
 - Secondary current

You can find additional information in chapters Operator control (Page 61) and Parameter assignment (Page 69).

Example

You want to measure in a 3P4W 10 kV system using voltage transformers (10000 V/100 V) and current transformers (100 A/5 A).

1. Select the "BASIC PARAMETERS" submenu of the "SETTINGS" menu.

Specify the connection type and the ratio of the voltage transformers you are using in the "VOLTAGE INPUT" menu item.

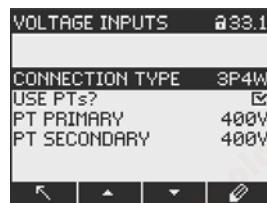

The ratio of the voltage transformer used can be adjusted only when the setting USE PTs? is activated.

2. Confirm your entry and press <ESC> to return to the "BASIC PARAMETERS" submenu.

Specify the ratio of the current transformers you are using in the "CURRENT INPUT" menu item.

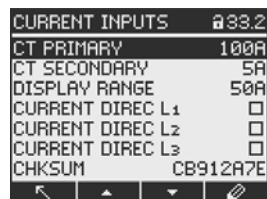

3. You can configure the resolution of the current display in the "DISPLAY RANGE" menu item.

The setting has no impact on the measurement accuracy of the device.

5.4 Applying the measuring voltage

The recommended setting is the current that is usually flowing in the system. If the usual current is 50 A, set the display range to 50 A. In this case, the current is displayed with one decimal place.

5.3.2 Additional settings

Language

After initial startup, the language of the text on the display can be set in the "LANGUAGE/REGIONAL" submenu of the "SETTINGS" menu.

Date/time

Date and time can be set in the "DATE/TIME" submenu of the "SETTINGS" menu.

Device protection against manipulation

In order to reduce the risk of manipulation occurring on the device, it is recommended that the protective mechanisms available in the device are activated.

For further information, please refer to chapter Security features (Page 87).

Please also note the information in chapters Operator control (Page 61) and Parameter assignment (Page 69).

5.4 Applying the measuring voltage

The power monitoring device is designed for operation with the following measuring voltages:

Rated voltage

- 57.7/100 ... 400/690 V ±20 % (IEC)
- 57.7/100 ... 347/600 V ±20 % (UL)

NOTICE

Observe the technical ratings.

The limits given in the technical data or on the rating plate must not be exceeded.

Measurement of DC voltage is not possible.

External voltage transformers are required to measure higher voltages than the permissible rated input voltages.

5.5 Applying the measuring current

The device is designed for connection of current transformers with secondary currents of 1 A and 5 A. It is only possible to measure alternating currents.

The current measuring inputs can each be loaded with 10 A continuously or with 100 A for 1 s.



! DANGER

Open transformer circuits will result in electric shock and arc flash hazards. Will cause death, serious personal injury, or equipment damage.

It is only possible to measure the current with external current transformers. Do **not** use fuses for circuit protection. Do not open the secondary circuit of the current transformers under load. Short circuit the secondary current terminals of the current transformer before removing this device. Follow the safety instructions for the applied current transformers.

NOTICE

Alternating current measurement only

Use the device to measure alternating current only.

Direction of current flow

Please take account of the direction of current flow when connecting the current measuring inputs. With inverse connection, the measured values are inverted and receive a negative sign.

To correct the direction of current flow, it is not necessary to reverse the input terminals. Instead, change the interpretation of the direction in the device settings.

You will find information about device settings in chapter Basic parameters (Page 72).

5.6 Checking the displayed measured values

Correct connection type

With the help of the table "Display of measured variables depending on the connection type", check whether the measured variables are displayed in accordance with the connection type executed. Any deviation indicates a wiring fault or configuration error.

Operator control

6.1 Device interface

6.1.1 Displays and operator controls

The following display and control elements (illustration shows the PAC3220, but the PAC3120 also has the same elements) are on the front panel of the power monitoring devices.

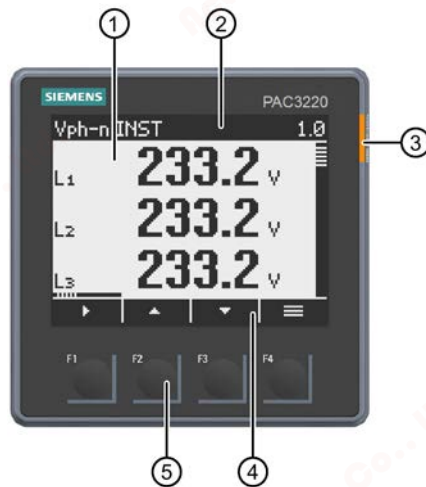

- ① Display area:
Displays the current measured values, device settings and selection menus.
- ② Header area:
Specifies the information visible in the display area.
- ③ Multi-colored LED:
Works like a normal digital output. The functions and color can be configured by the user.
- ④ Footer area:
Specifies the functions assigned to the function keys.
- ⑤ Surfaces of the function keys:
The keys have multiple assignments. Function assignments and key labeling change according to the context of operator input. The designation of the current key function can be seen above the key number in the footer area of the display.
A short press on the key triggers the function once. Holding the key down for longer switches on the autorepeat function after approximately 1 s. The function of the key is triggered repeatedly while the key is held down. Autorepeat is useful, for example, for fast incrementing of values when parameterizing the device.

Figure 6-1 Device interface

6.1.2 Special display elements

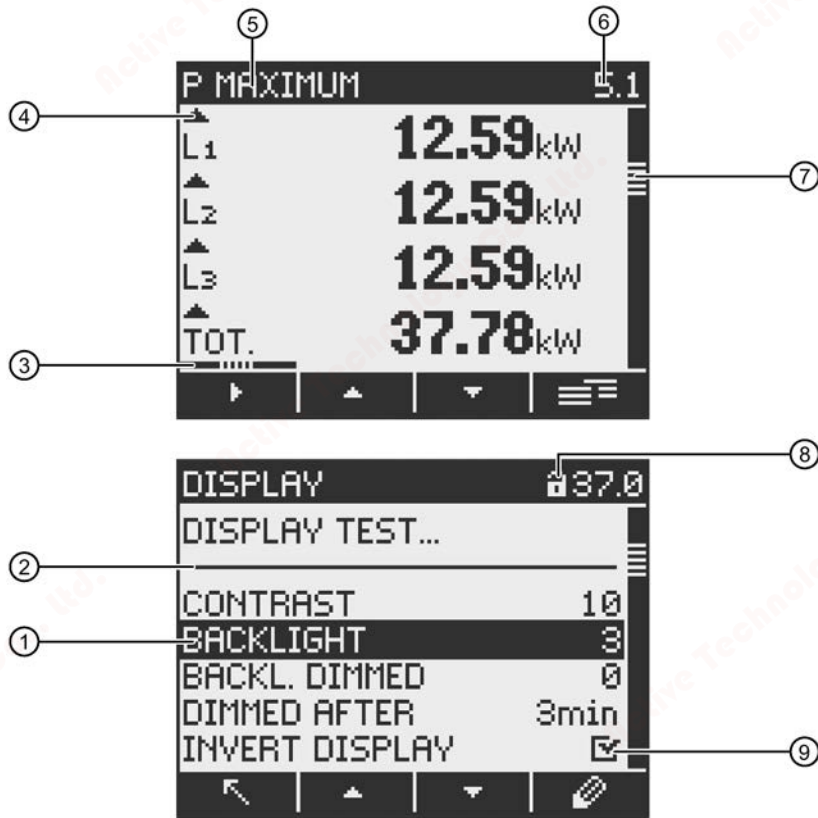

- ① Selection bar
- ② Line separating the start and end of the list
- ③ Scroll bar of function key F1 (multiple assignments of key F1)
- ④ Arrow up: Maximum value
Arrow down: Minimum value
- ⑤ Menu name
- ⑥ Menu number
- ⑦ Scroll bar (display can be scrolled upwards/downwards)
- ⑧ Device protection symbol
 - Open padlock: Protection deactivated
 - Closed padlock: Protection activated
- ⑨ Activation/deactivation symbol
 - Symbol with check mark: function activated
 - Symbol without check mark: function deactivated

Figure 6-2 Special display elements

6.1.3 LED

The multi-colored LED works like a normal digital output. The user can configure the function, the color and the brightness of the LED.

Function





Functions	
Device ON	The brightness of the LED changes gradually.
Remote control	The LED signals remote access to the device. The LED remains illuminated for as long as remote access to the device is active, or until the set time expires. TIMEOUT: 0 ... 18000 s (Timeout 0 s: the LED remains illuminated while remote access is active.)
Direction of rotation	The LED reacts to the direction of rotation of the electrical field. <ul style="list-style-type: none"> ●: Counter-clockwise rotating field ○: Clockwise rotating field The color and lighting behavior of the LED can be adjusted individually. Possible lighting behavior: <ul style="list-style-type: none"> • OFF • ON • Flashing fast/slow • Flashing with variation in brightness
Energy pulse	The LED flashes 1000 x / unit Possible units: <ul style="list-style-type: none"> • kWh import • kWh export • kvarh import • kvarh export

Functions	
Remote-controlled color	<p>The LED can be switched on by a Modbus command.</p> <p>The LED remains illuminated until the OFF command is registered, or until the set time expires.</p> <p>TIMEOUT: 0 ... 18000 s</p> <p>(Timeout 0 s: the LED remains illuminated until the OFF command is received.)</p>
DI status	<p>The LED reacts to changes in the status of the digital input.</p> <p>The color and lighting behavior of the LED can be adjusted individually.</p> <p>Possible lighting behavior:</p> <ul style="list-style-type: none"> • OFF • ON • Flashing fast/slow • Flashing with variation in brightness

Color

- White
- Yellow
- Green
- Blue
- Red
- Orange
- Cyan
- Violet

Lighting behavior

Lighting behavior	
OFF	LED is continuously OFF.
ON	LED is continuously ON.
	LED flashes quickly with varying brightness level.
	LED flashes slowly with varying brightness level.
	LED flashes quickly with constant brightness.
	LED flashes slowly with constant brightness.

6.1.4 Menu navigation

The menu-based navigation is intuitive and largely self-explanatory. Only the basic structure of the menu-based navigation will be explained below. The description and function of the individual parameters can be found in chapter Parameter assignment (Page 69).

Menu levels

The device menu can be subdivided into four menu levels:

- Measured value level
- Main menu level
- Setting level
- Editing level

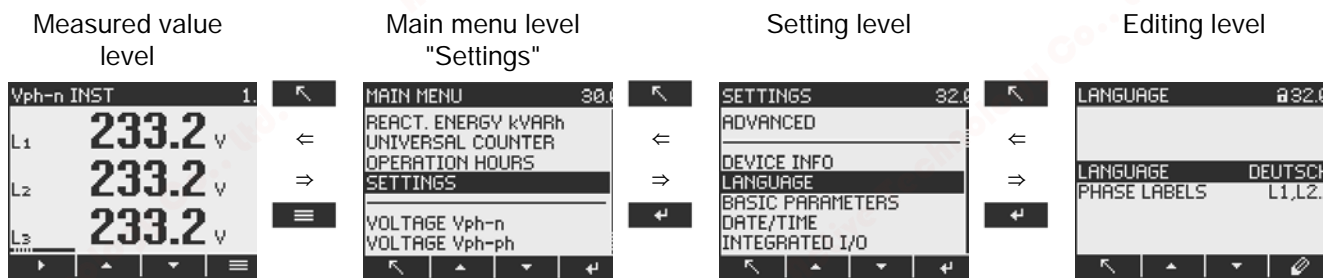

Depending on the device version and firmware status, the availability of the measured values may vary in the measured value and main menu levels. The parameter selection options at the setting and editing levels also depend on the device version and firmware status.

6.1.4.1 Measured value level





By default, the device is at the measured value level.

At the measured value level, the available measured values can be read off. The display shows the measured values of the currently selected measured variable. (All possible measured values are listed in the table in chapter Measuring inputs (Page 17). The selection of measured values depends on the device version and connection type.)

- The and keys can be used to scroll through the measured values.
- The key can be used to call additional information.
- The key can be used to take the device to the main menu level.

6.1.4.2 Main menu level





In this menu level, all available measured variables are listed without measured values. The **main menu level** also has a "SETTINGS" selection menu item which can be used to configure the device.

- The  key returns the device to the **measured value level**.
- The  and  keys can be used to scroll between menu items.
- The  key confirms the selection made and takes the device to the measured value level.

In the "SETTINGS" menu option, the device is taken to the "Setting level" by means of the  key.











6.1.4.3 Setting level

At the setting level the device can be configured. At this menu level, all settable parameters are listed.

- The  key returns the device to the main menu level.
- The  and  keys can be used to scroll through the settable parameters.
- The  key confirms the selection made and takes the device to the **editing level**.













6.1.4.4 Editing level

At the **editing level**, it is possible to modify the device parameters.

- The  key returns the device to the **setting level**.
- The  and  keys can be used to navigate to the value to be changed.
- The  or  key can be used to select a value for editing.
- The  and  keys, or  and  keys are used to alter the value.
- The  key confirms the change and takes the device to the measured value level.

6.1.5 Control keys

The device can be operated by means of four keys. The keys are assigned different functions. The functions of the keys depend on the menu level currently in use.

Keys	Possible assignment	Meaning
F1		Measured value level: The user uses this key to navigate to the next submenu. Additional measured data for the selected measured value are displayed in the submenu.
		This key causes all inputs to be discarded and returns the device to the last menu displayed. Any changes made but not confirmed are not transferred to the system.
F2		Measured value level: This key calls the next measured variable to the display. Main menu and setting levels: This key moves the selection bar upwards.
		Editing level: Displays the next selectable setting or increases the numerical value by "1".
F3		Measured value level: This key calls the next measured variable to the display. Main menu and setting levels: This key moves the selection bar downwards.
		Editing level: Displays the next selectable setting.
		Editing level: Selects the next number from the right for editing.
F4		Measured value level: This key activates the main menu.
		Measured value level: The submenu is currently selected on the device. This key activates the main menu. Holding the key down for a prolonged period activates a context menu in which, for example, it is possible to reset minimum or maximum values.
		Main menu and setting levels: This key confirms the selection made. Editing level: This key confirms the changes made to parameters.
		The key can be used to take the device to the editing level.
		Editing level: This key activates or deactivates a function.

Parameter assignment

7.1 Introduction

Device settings

The chapter headed "Parameterizing" describes the device settings. These include:

- Adjustment to the physical conditions of use
- Integration into the communication system
- Country-specific settings, ergonomics, device protection

It is possible to set the device by means of:

- The operator interface of the device
- Powerconfig configuration software

Note

Protection of the device settings

As delivered, the device settings are not protected. At startup, a password should be assigned and the device protection activated to guard against unauthorized or inadvertent changes.

7.2 Parameterizing via the operator interface

The power monitoring device can be parameterized via the "Settings" menu option.

You can find more information in chapter Menu navigation (Page 65).

The device settings are arranged into the following groups. The "SETTINGS" menu shows the choice of groups:

- Device information
 - Article number and versions
- Language
 - Display language and designation of the phases on the display
- Basic parameters
 - Settings for the measuring inputs, averaging time of the sliding window demand
- Date/time
 - Time-related settings
- Integrated I/Os
 - Settings for using the digital inputs and outputs
- Communication
 - Network communication settings
- Display
 - Settings for the display
- Energy counters
 - Energy counter settings (balance, import or export)
- Advanced
 - Password protection, device reset, write protection

7.2.1 Device information

The device information cannot be modified.

Device information	
7KM3x20-xBA01-1xA0	Article number of the device
PAC3x20	Device designation
S/N: LQN/230823xxxxxx	Serial number of the device
D/T: xxxxxx	Date code
ES: xxx	Hardware revision level
SW-REV: xxxx	Firmware revision level
BL-REV: xxxx	Boot loader revision level
LP-REV: xxxx	Language pack revision level

7.2.2 Language

The language of menu-based operation and of the measured value displays can be set in the "Language" menu item.

Selection	Range	Factory setting
Language	<ul style="list-style-type: none"> • Chinese • German • English • French • Italian • Portuguese • Polish • Russian • Spanish • Turkish 	English
Phase labels	<ul style="list-style-type: none"> • L1 L2 L3 • a b c 	L1 L2 L3

7.2.3 Basic parameters

Measuring inputs can be parameterized in the "Basic parameters" menu item.

Voltage input

Selection	Range	Factory setting
Connection type	<ul style="list-style-type: none"> • 3P4W: 3 phases, 4 conductors • 3P3W: 3 phases, 3 conductors • 3P4WB: 3 phases, 4 conductors, balanced load • 3P3WB: 3 phases, 3 conductors, balanced load • 1P2W: 1 phase, 2 conductors 	3P4W
Use PTs?	<ul style="list-style-type: none"> • <input checked="" type="checkbox"/> ON: Measurement using voltage transformers. When measuring via voltage transformers, the device must know the voltage transformation ratio. For this purpose, the primary and secondary voltages must be specified in the fields "PT PRIMARY" and "PT SECONDARY". When changing from direct measurement to measurement using voltage transformers, the device accepts the last set reference measuring voltage as the secondary voltage and as the primary voltage. • <input type="checkbox"/> OFF: Measurement directly on the low-voltage system. When changing from measurement using voltage transformers to direct measurement, the device accepts the last set secondary voltage as the reference measuring voltage. 	<input type="checkbox"/> OFF
PT PRIMARY (Use PTs? <input checked="" type="checkbox"/> ON)	1 ... 999999 V, freely adjustable	400 V
PT SECONDARY (Use PTs? <input checked="" type="checkbox"/> ON)	1 ... 4000 V, freely adjustable	400 V

Current input

Selection	Range	Factory setting
CT PRIMARY	Primary current of the current transformers 1 ... 99999 A	50 A
CT SECONDARY	Secondary current of the current transformers <ul style="list-style-type: none"> • 1 A • 5 A 	5 A
DISPLAY RANGE:	Freely adjustable 1 ... 99999 A	50 A
<ul style="list-style-type: none"> • CURRENT DIREC L1 • CURRENT DIREC L2 • CURRENT DIREC L3 	Inverse evaluation of the current flow direction separately for each phase. <ul style="list-style-type: none"> • <input checked="" type="checkbox"/> ON: Direction of current flow is inverted. The device interprets the current flow direction as opposite to the wiring. • <input type="checkbox"/> OFF: The device interprets the current flow direction to match the wiring. 	<input type="checkbox"/> OFF

7.2.4 Date/time

Setting the date and time

Selection	Range	Factory setting
DATE	Current date. The date format is defined in the FORMAT field.	–
FORMAT	<ul style="list-style-type: none"> • DD.MM.YYYY • YYYY-MM-DD • MM/DD/YY 	DD.MM.YYYY
TIME	HH:MM:SS	–
TIME ZONE	Time zone, refers to coordinated universal time (UTC). –12:00 ... +14:00, in 30-minute intervals Examples: <ul style="list-style-type: none"> • "–06:00" corresponds to UTC-6 • "+01:00" corresponds to UTC+1 	00:00

Selection	Range	Factory setting
DAYL.SAVING	<p>Automatic time change.</p> <ul style="list-style-type: none"> • OFF: Time change is switched off. • AUTO EU: Time change within the European Union The internal clock is put forward from 1 a.m. UTC to 2 a.m. UTC on the last Sunday in March. Changeover to standard time: The internal clock is put back from 2 a.m. UTC to 1 a.m. UTC on the last Sunday in October. • AUTO US: Time change within the USA The internal clock is put forward from 2 a.m. local time to 3 a.m. on the second Sunday in March. Changeover to standard time: The internal clock is put back from 2 a.m. local time to 1 a.m. on the first Sunday in November. • TABLE: Time change can be individually parameterized. The parameters can be set in the software. 	AUTO EU
SNTP (applies only to PAC3220)	<p>Protocol is used for transmitting the time and for synchronization.</p> <ul style="list-style-type: none"> • OFF: SNTP function deactivated. • ACTIVE: The device automatically requests the time from the NTP server. • BCST Client: The device receives time frames which are sent from an NTP server. 	OFF
IP (only when SNTP is activated) (applies only to PAC3220)	<p>If an SNTP IP address is configured, only data from this IP address is accepted. 0.0.0.0</p>	0.0.0.0

7.2.5 Integrated I/Os

Device settings for using the digital inputs and outputs.

Digital output

Selection	Range	Factory setting
DIG. OUTPUT	Two digital outputs are available: <ul style="list-style-type: none"> • 0.0 • 0.1 	–
ACTION	<ul style="list-style-type: none"> • OFF: Output is deactivated. • DEVICE ON: Output signals that the device is switched on. • REMOTE CONTROL: Output is controlled by remote access. • DIRECTION OF ROTATION: Output is activated by a clockwise rotating electrical field and remains active for as long as the field is rotating in this direction. • PULSE: Output outputs the parameterized number of pulses or edges per energy unit. 	OFF
PULSES	Number of pulses to be output per unit. The reference unit is defined in the "UNIT" field. 1 ... 4000	1
UNIT (with PULSE only)	Selects the type of cumulated power (active energy or reactive energy): <ul style="list-style-type: none"> • kWh IMPORT • kWh EXPORT • kvarh IMPORT • kvarh EXPORT The reference values at which a pulse or an edge is output are defined in the fields "UNIT" and "PULSES PER UNIT". Value of the cumulated power for which a configurable number of pulses is output. The number of pulses to be output is defined in the field "PER". <ul style="list-style-type: none"> • 1 kVarh or kW • 10 kVarh or kW • 100 kVarh or kW • 1000 kVarh or kW 	kWh IMPORT

7.2 Parameterizing via the operator interface





Selection	Range	Factory setting
PER (with PULSE only)	Value of the cumulated power for which a configurable number of pulses is output. The number of pulses to be output is defined in the field "PER". <ul style="list-style-type: none">• 1• 10• 100• 1000	1
PULSE LENGTH	Length of the pulse: 30 ... 500 ms The minimum length of the pulse pause corresponds to the pulse duration specified.	100 ms
LIM CH. (with LIM.VIOLATION only)	Selects the limit whose status is output to the digital output. <ul style="list-style-type: none">• LIMIT LOGIC• LIM 0 ... 5	LIMIT LOGIC

Digital Input

Selection	Range	Factory setting
DIG. INPUT	Two digital inputs are available: <ul style="list-style-type: none"> • 0.0 • 0.1 	–
ACTION	<ul style="list-style-type: none"> • NONE: The input is switched off. • PULSE INPUT: Counting of input pulses. (Note: A universal counter can be parameterized for pulse counting. In the device settings "ADVANCED > UNIVERSAL COUNTER", set the field "SOURCE" to the value "DIG. INPUT".) • ON/OFF-PEAK: Tariff switching. Low tariff if input active. • DEMAND SYNC: Synchronization of power demand. • LIM.VIOLATION: The output is switched on by a limit violation and remains active while the limit violation prevails. • PULSE: Output outputs the parameterized number of pulses or edges per energy unit. 	OFF
PULSES	Number of pulses to be output per unit. The reference unit is defined in the "UNIT" field. 1 ... 4000	1

LED

Selection	Range	Factory setting
ACTION	<ul style="list-style-type: none"> • OFF: The LED is switched off. • DEVICE ON: The LED signals that the device is switched on. The brightness of the LED changes gradually. • REMOTE CONTROL: The LED signals remote access to the device. The color of the LED can be freely chosen from a selection of colors. The lighting behavior of the LED can be selected from a range of options. • DIRECTION OF ROTATION: The LED reacts to the direction of rotation of the electrical field. The color of the LED can be freely chosen from a selection of colors. The lighting behavior of the LED can be selected from a range of options. • PULSE: The LED outputs 1000 LED pulses per energy unit. The color of the LED can be freely chosen from a selection of colors. • REMOTE COLOR: The LED can be switched on by a Modbus command. • DI STATUS: The LED signals the status of the digital input. The color of the LED can be freely chosen from a selection of colors. The lighting behavior of the LED can be selected from a range of options. 	PULSE
PULSES (with PULSE only)	Number of pulses to be output per unit. The reference unit is defined in the "UNIT" field. 1000 (not variable)	1000
TIMEOUT (with REMOTE CONTROL and REMOTE COLOR only)	The LED switches off at the end of the defined timeout period. 0 ... 18000 s	0 s
BRIGHTNESS	Luminous intensity of the LED 0 ... 4	4

Selection	Range		Factory setting
Colors	<ul style="list-style-type: none"> • ORANGE • GREEN • CYAN • BLUE • VIOLET • WHITE • RED • YELLOW 		ORANGE
Lighting behavior	OFF	LED is continuously OFF.	ON
	ON	LED is continuously ON.	
		LED flashes quickly with varying brightness level.	
		LED flashes slowly with varying brightness level.	
		LED flashes quickly with constant brightness.	
		LED flashes slowly with constant brightness.	

Status

Selection	Range	Factory setting
DI 0. DO 0.	Graphically represents the status of the integrated I/Os on the device display.	–

7.2.6 Communication

RS485 interface (applies only to PAC3120 or PAC3220 with RS485 expansion module)

Table 7- 1 RS485 interface (applies only to PAC3120)

Selection	Range	Factory setting
ADDRESS	Range: 1 ... 247	126
BAUD RATE	Range: <ul style="list-style-type: none">• 4800• 9600• 19200• 38400• 57600• 115200	19200
FORMAT	<ul style="list-style-type: none">• 8N1• 8N2• 8E1• 8O1	8N2
RESPONSE TIME	Range: 0 ... 255 ms	0 ms

Ethernet interface (applies only to PAC3220)

Table 7- 2 Ethernet interface (applies only to PAC3220)

Selection	Range	Factory setting
MAC	MAC address. Read only.	–
IP	Manual setting of the IP address is only possible when DHCP is deactivated. Format: 000.000.000.000	–
SN	Manual setting of the subnet is only possible when DHCP is deactivated. Format: 000.000.000.000	–
DHCP	(Dynamic Host Configuration Protocol) If DHCP is activated, network configurations are automatically assigned. This enables automatic integration of devices into an existing network. If DHCP is activated, network configurations cannot be adjusted manually.	<input checked="" type="checkbox"/> ON
IP FILTER	The IP filter is a configurable access protection. When the IP filter is activated, Modbus TCP write commands are only accepted if the remote station is located in the same subnet. <ul style="list-style-type: none"> • ON: Access to the device is refused if the request comes from an uncleared host. • OFF: IP filter deactivated 	<input type="checkbox"/> OFF
Modbus PORT	0 ... 65534 The setting Modbus port = 0 deactivates the Modbus TCP server.	502
HTTP PORT	Manual setting of the HTTP port (web server). With the HTTP port = 0 setting, the web server is deactivated.	80
GW	Manual setting of the gateway is only possible when DHCP is deactivated. In the case of data exchange with an IP address which is not in the home subnet, the data can be transmitted via a gateway. It interconnects different networks. Format: 000.000.000.000	--

7.2.7 Display

Selection	Range	Factory setting
CONTRAST	Contrast of the LC display. 0 ... 10	5
BACKLIGHT	Intensity of the backlighting of the LC display. 0 ... 3	3
BACKL.DIMMED	Intensity of the backlighting of the LC display. Set by the device after the "time until dimmed" expires. See "TIME UNTIL DIMMED" field. 0 ... 3 (“0” switches the backlighting off.)	1
DIMMED AFTER	Time after which the device switches the backlighting from "BACKLIGHT LEVEL" to "BACKL.DIMMED". 0 ... 99 min	3 min
INVERT DISPLAY	Inversion of the basic representation of the display. <ul style="list-style-type: none"> <input checked="" type="checkbox"/> ON: Dark text on light background <input type="checkbox"/> OFF: Light text on dark background 	<input checked="" type="checkbox"/> ON
DISPLAY TEST...	Screen for testing the functional capability of the display. <ul style="list-style-type: none"> Key F3 inverts the test screen. Key F4 closes the display. 	–
DEFAULT MENU	Menu display number for the default menu. The device always starts up with the menu display defined here. 1 ... xx	1
TIMEOUT	When the specified time has elapsed, the device automatically returns to the defined default menu. 0 ... 3600 s (0 = function deactivated)	0

7.2.8 Advanced

7.2.8.1 Password

Password protection prevents the following actions:

- Changing of device settings, including password
- Changing and deletion of values
- Deletion of data and memory content
- Setting and resetting of counts
- Resetting to factory settings

Reading out of measured values and memory content is possible without restriction when password protection is active.

Note

It is possible to define in the menu whether the password protects only the display **or** the communication interfaces, or whether it **simultaneously** protects the display and the communication interfaces.

Selection	Range	Factory setting
DISPLAY	Password protection prevents write access via the device interface. <ul style="list-style-type: none"> • <input checked="" type="checkbox"/> ON: Password protection active • <input type="checkbox"/> OFF: Password protection deactivated 	<input type="checkbox"/> OFF
COMMUNICATION	Password protection prevents write access via the communication interfaces. <ul style="list-style-type: none"> • <input checked="" type="checkbox"/> ON: Password protection active • <input type="checkbox"/> OFF: Password protection deactivated 	<input type="checkbox"/> OFF
PASSWORD	0000 ... 9999	0000

Note

If you have forgotten the password, please contact Technical Support. You will be issued with a new password.

7.2.8.2 Write protection

The hardware write protection prevents write access to the device, both via the communication interface and on the display.

In order to gain write access, the hardware write protection must be deactivated directly on the device. The hardware write protection cannot be deactivated via a communication port. The user must adjust the position of the write protection slider on the rear panel of the device in order to activate or deactivate the hardware write protection function.

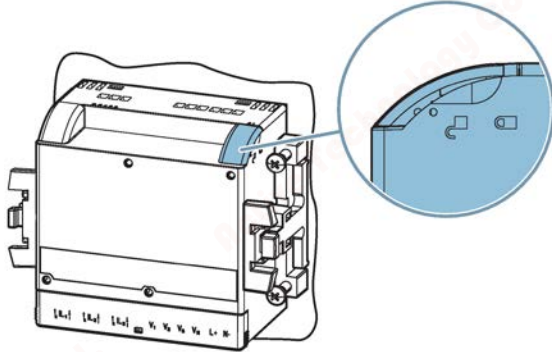

Selection	Range	Factory setting
WRITE PROTECTION	Write access is not possible when the hardware write protection is activated. This parameter is solely a display parameter. The position of the mechanical slider on the rear panel of the device must be adjusted in order to activate or deactivate the protection function.	–
DISPLAY*	Write protection prevents write access via the device interface. <ul style="list-style-type: none"> <input checked="" type="checkbox"/> ON: Write protection active <input type="checkbox"/> OFF: Write protection deactivated 	<input type="checkbox"/> OFF
CLEAR MIN/MAX VALUES*	Minimum/maximum values are protected by the write protection function. <ul style="list-style-type: none"> <input checked="" type="checkbox"/> ON: Write protection active <input type="checkbox"/> OFF: Write protection deactivated 	<input type="checkbox"/> OFF
DATE/TIME*	The date and time are protected by the write protection function. <ul style="list-style-type: none"> <input checked="" type="checkbox"/> ON: Write protection active <input type="checkbox"/> OFF: Write protection deactivated 	<input type="checkbox"/> OFF
PASSWORD*	The password is protected by the write protection function. <ul style="list-style-type: none"> <input checked="" type="checkbox"/> ON: Write protection active <input type="checkbox"/> OFF: Write protection deactivated 	<input type="checkbox"/> OFF
COMMUNICATION*	Write protection prevents write access via the communication interface. <ul style="list-style-type: none"> <input checked="" type="checkbox"/> ON: Write protection active <input type="checkbox"/> OFF: Write protection deactivated 	<input type="checkbox"/> OFF
LIMITS*	Limits are protected by the write protection function. <ul style="list-style-type: none"> <input checked="" type="checkbox"/> ON: Write protection active <input type="checkbox"/> OFF: Write protection deactivated 	<input type="checkbox"/> OFF

* can be parameterized only when the write protection slider is in the "open" position

7.2.8.3 Resetting

Selection	Range	Factory setting
CLEAR MIN/MAX VALUES	Resets all minimum and maximum values to the instantaneous value. <ul style="list-style-type: none"> • <input checked="" type="checkbox"/> Yes: active • <input type="checkbox"/> No: not active 	<input type="checkbox"/> No
RESET COUNTERS	Resets the following counters to zero (0): <ul style="list-style-type: none"> • Energy counters • Active energy • Reactive energy • Apparent energy • Operating hours counter <ul style="list-style-type: none"> • <input checked="" type="checkbox"/> Yes: active • <input type="checkbox"/> No: not active 	<input type="checkbox"/> No
UNIV. COUNTER RESET	Resets the configurable universal counter to zero (0). <ul style="list-style-type: none"> • <input checked="" type="checkbox"/> Yes: active • <input type="checkbox"/> No: not active 	<input type="checkbox"/> No
FACTORY DEFAULTS	All device settings and measured values except the communication parameters and energy secondary values are reset to the as-delivered condition. <ul style="list-style-type: none"> • <input checked="" type="checkbox"/> Yes: active • <input type="checkbox"/> No: not active 	<input type="checkbox"/> No
COMMUNICATION PARAMETERS	All communication settings are reset to the as-delivered condition. <ul style="list-style-type: none"> • <input checked="" type="checkbox"/> Yes: active • <input type="checkbox"/> No: not active 	<input type="checkbox"/> No
EXECUTE	Confirmation of the reset	–

Note



The reset must be confirmed by selecting the "Execute" field. Otherwise the device reset is not executed.

Security features

The devices are equipped with a range of mechanisms to protect against deliberate and inadvertent device manipulation.

- Password protection
- Hardware write protection
- Device access control (IP filter) (PAC3220 only)
- Configurable Modbus TCP port (PAC3220 only)

The closed padlock symbol in the display title indicates whether "password protection" or "hardware write protection" is activated.

-  Device is protected against write access.
-  Device is not protected against write access.

Note

It is advisable to activate the manipulation protection mechanisms in the device.

8.1 Password protection

Password protection prevents write access via the device interface and the communication interfaces, in particular:

- Changing of device settings, including password
- Changing and deletion of values/parameters
- Deletion of data and memory content
- Setting and resetting of counts
- Resetting to factory settings

Reading out of measured values and memory content is still possible when password protection is active.

The password can be activated on the device in the "Advanced" submenu of the "Settings" menu.

8.1 Password protection

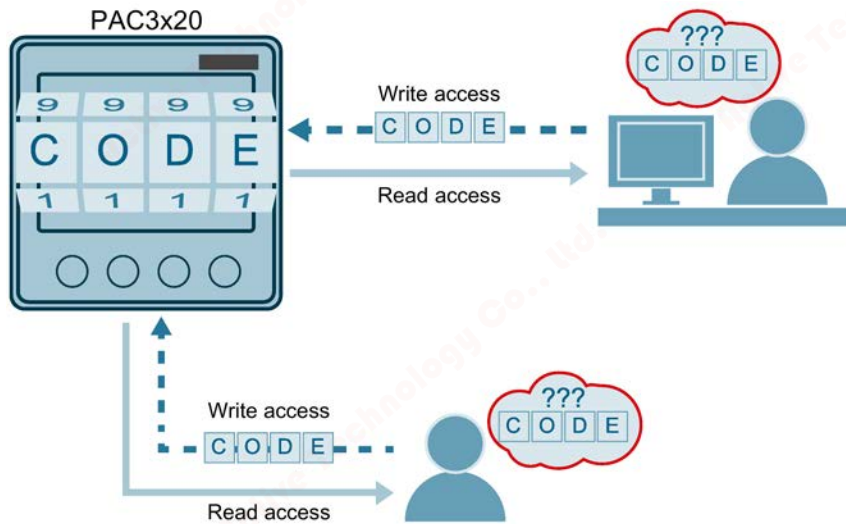

As soon as the password has been entered in the device once, it is not requested again as long as the "Settings" menu level remains active.

Password policy: four-digit number from 0000 to 9999 (default password: 0000)

If no user-specific password has been assigned, the default password must be entered when password protection is switched on.

The currently valid password becomes visible on the display when password protection is switched off. The password remains saved and becomes effective again the next time password protection is switched on.

Note

Before you switch on password protection, make sure that you and the group of authorized users are all in possession of the password. If password protection is switched on, the password is mandatory for all changes to the device settings. You also require the password to call the "PASSWORD" dialog box again in order to switch off access protection or to change the password.

Note

If you have forgotten the password, please contact Technical Support (Page 8). You will be issued with a new password.

8.2 Hardware write protection

The hardware write protection prevents write access to the device, both via the communication interface and on the display.

In order to gain write access, the hardware write protection must be deactivated directly on the device.

The hardware write protection cannot be deactivated via a communication interface.

The hardware write protection can be activated on the device and parameterized in detail in the **"Advanced"** submenu of the **"Settings"** menu. A list of the various setting options can be found in chapter Write protection (Page 84).

Note

The user must adjust the position of the write protection slider on the rear panel of the device in order to activate or deactivate the hardware write protection function (see chapter Write protection (Page 84)).

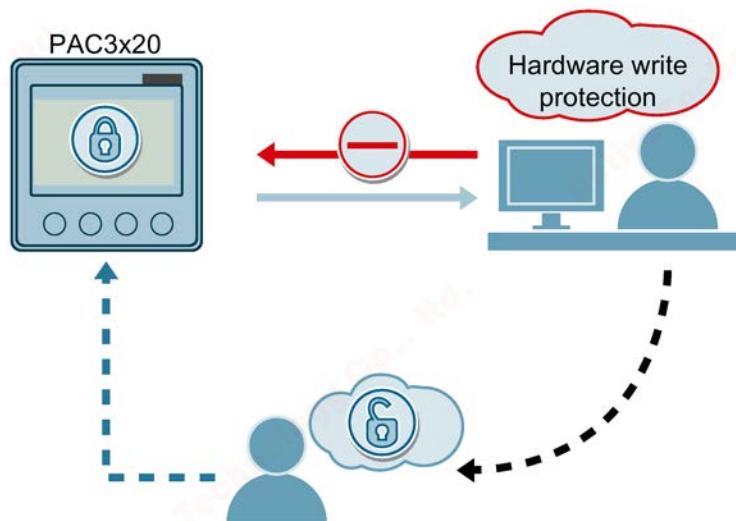

Note

It is advisable to activate the hardware write protection on the device.

8.3 Device access control (IP filter) (PAC3220 only)

This function is only available on the PAC3220.

The IP filter is a configurable access protection. When the IP filter is activated, Modbus TCP write commands are only accepted if the remote station is located in the same subnet.

The IP filter can be activated on the device in the "Communication" submenu of the "Settings" menu.

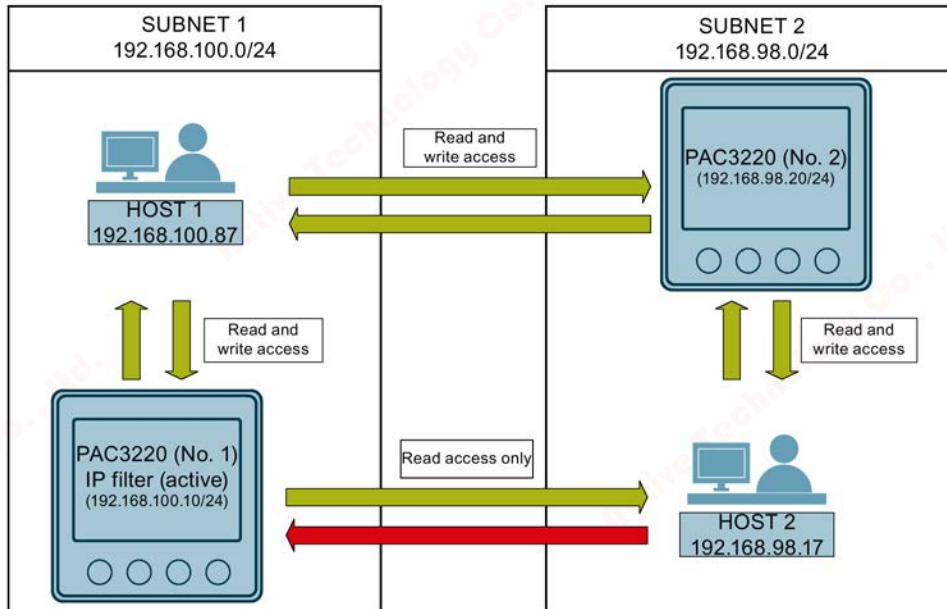

Note

Switching from standard port 502 to a user-defined port makes it more difficult to scan for open ports.

Example

PAC3220 No. 1 **with IP filter** is located in subnet 1 (192.168.100.0/24).

PAC3220 No. 2 **without IP filter** is located in subnet 2 (192.168.98.0/24).

- Host 1 (IP: 192.168.100.87) in subnet 1 (192.168.100.0/24) has read and write access to PAC3220 No. 1 (192.168.100.10/24), because Host 1 is located in the same subnet as the PAC device.
- Host 1 (IP: 192.168.100.87) in subnet 1 (192.168.100.0/24) has read and write access to PAC No. 2 (192.168.98.20/24) in subnet 2 (192.168.98.0/24), because the IP filter is not activated on PAC No. 2.
- Host 2 (IP: 192.168.98.17) in subnet 2 (192.168.98.0/24) has read only access to PAC No. 1 (192.168.100.10/24), because the IP filter is activated on PAC No. 1 and Host 2 is not located in the same subnet as PAC No. 1.

8.4 Configuring the Modbus TCP port (PAC3220 only)

This function is only available on the PAC3220.

Ports are communication channels which make it possible to access a Modbus-capable device via a network. Standard IP ports like port 502 are often tested by port scanners. If an open port is discovered by an attacker, it can be used to attack the device.

For this reason, the PAC3220 allows the Modbus TCP port to be configured manually.

The IP filter can be activated on the device in the "Communication" submenu of the "Settings" menu.

8.4 Configuring the Modbus TCP port (PAC3220 only)

Service and maintenance

9.1 Cleaning

Clean the display and the keypad periodically. Use a dry cloth for this.

NOTICE
Damage due to detergents
Detergents can damage the device. Do not use detergents.

9.2 Firmware update

The power monitoring devices support firmware updates.

Use the powerconfig configuration software to update the firmware. Additional information on updating the firmware can be found in the online help for powerconfig.

You can protect the update function, like all write accesses, with a password.

NOTICE
Power failure during a firmware update renders the device unable to function.
The firmware update takes several minutes. Connect the devices to a fail-safe power supply before updating the firmware.
If the power fails despite this security measure, try to restart the firmware update of the PAC power monitoring device in powerconfig.

9.3 Warranty

Procedure

Note

Loss of warranty

Opening the device invalidates the Siemens warranty. Only the manufacturer is permitted to carry out repairs to the device.

If the device is defective or damaged, proceed as follows (only during the warranty period):

1. Deinstall the device. You can find more information in chapter Deinstallation (Page 38).
2. Pack the device in a suitable manner to prevent it from being damaged during transport.
3. Return the device to Siemens. You can obtain the address from:
 - Your Siemens sales partner
 - Technical Assistance (Page 8)

Disposal of waste electronic equipment



Waste electronic equipment must not be disposed of as unsorted municipal waste, e.g. household waste. When disposing of waste electronic equipment, the current local national/international regulations must be observed.

Technical data

10.1 Technical data

Device configuration

- 2 opto-isolated digital inputs
- 2 opto-isolated digital outputs
- 1 RS485 interface for connecting to a PC or network (PAC3120 only)
- 2 Ethernet interfaces for connecting to a PC or network (PAC3220 only)

Measurement

Only for connection to AC voltage systems.

Measurement		
Measuring method	Voltage measurement	True RMS measurement (TRMS), zero blind measurement, gapless
	Current measurement	True RMS measurement (TRMS), zero blind measurement, gapless
Measured value acquisition	<ul style="list-style-type: none"> • Power • Frequency • Power factor • $\cos \varphi$ 	Zero blind measurement, gapless
	Waveform	Sinusoidal or distorted
	Frequency of the relative fundamental	50/60 Hz
	Measured value acquisition mode	Automatic line frequency detection

Measuring inputs for voltage

Measuring inputs for voltage		
Measurable voltage	Rated voltage	57.7/100 ... 400/690 V (IEC)
		57.7/100 ... 347/600 V (UL)
	Min. measuring voltage U_{L-N}	11.5 V
	Max. measuring voltage U_{L-N}	480 V (IEC) 416 V (UL)
Zero point suppression level	Voltage L-N	10 V
	Voltage L-L	17 V
Measuring category (acc. to IEC/UL 61010-2-030)	Category	CAT III
	Impulse withstand voltage	≥ 9.6 kV (1.2/50 μ s)
Input resistance (L N)		1.5 M Ω
Max. power consumption per phase		150 mW

Measuring inputs for current

Only for connection to AC power systems via external current transformers.

Measuring inputs for current		
Input current I_E	Rated current 1	x/1 A
	Rated current 2	x/5 A
Measuring range of current		10 ... 120 % of rated current
Measuring range for power and energy measurement		1 ... 120 % of rated current
Surge withstand capability		100 A for 1 s
Max. permissible continuous current		10 A
Max. power consumption per phase		300 mVA at 5 A
Zero point suppression level		0 ... 10 % of rated current

Measuring accuracy

Applied standards:

- IEC 61557-12
- IEC 62053-21
- IEC 62053-22
- IEC 62053-23

Measuring accuracy	
Measured variable	Accuracy class acc. to IEC 61557-12
Voltage	0.2
Current	0.2
Apparent power	0.5
Active power	0.5
Reactive power	1
Total apparent power over all phases	0.5
Total active power over all phases	0.5
Total reactive power VAR1 over all phases	1
Cumulated active power	0.5
Cumulated reactive power	1
Total power factor	0.5
Line frequency	0.05
Active energy	0.5
Reactive energy	2
THD	5

When measuring on external current transformers or voltage transformers, the accuracy of the measurement depends on the quality of the transformers.

Supply voltage

Supply voltage		
Wide-range AC/DC power supply unit	Rated range PAC3220	100 ... 250 V AC/DC \pm 10 %, 50/60 Hz 8 VA
	Rated range PAC3120	100 ... 250 V AC/DC \pm 10 %, 50/60 Hz 4 VA
Extra-low voltage DC power supply unit	Rated range PAC3220	24 ... 60 V DC \pm 20 % 8 VA
	Rated range PAC3120	24 ... 60 V DC \pm 20 % 4 VA
Overvoltage category		OVC III

Digital inputs

Digital inputs		
Number		2
Input voltage	Rated value	24 V DC
	Maximum input voltage	30 V DC
	Switching thresh. signal "1"	> 11 V DC
Input current	For "1" signal	Typ. 7 mA

Digital outputs

Digital outputs		
Number		2
Type		Bidirectional
Design/function		Switching output or pulse output
Rated voltage		0 ... 30 V DC, typical 24 V DC (SELV or PELV supply)
Output current	For "1" signal	Depends on the load and the external power supply
	Continuous load	≤ 50 mA (thermal overload protection)
	Transient overload	≤ 130 mA for 100 ms
	For "0" signal	≤ 0.2 mA
	Internal resistance	55 Ω
Pulse output function	Standard for pulse emitter	Signal characteristics in accordance with IEC 62053-31
	Adjustable pulse duration	30 ... 500 ms
	Min. settable time frame	10 ms
	Max. switching frequency	17 Hz
	Short-circuit protection	Yes

Communication PAC3120

Communication PAC3120

RS485 interface	Electrical interface	RS485, two-wire line + 1 line for Common
	Connection type	Screw terminals
	Supported communication protocol	Modbus RTU
	Functionality	Slave
	Supported baud rate	<ul style="list-style-type: none"> • 4800 • 9600 • 19200 • 38400 • 57600 • 115200 Default: 19200
	Data format	<ul style="list-style-type: none"> • 8N1 • 8N2 • 8E1 • 8O1 Default: 8N2
	Supported address area	1 ... 247 Default: 126

Communication PAC3220









Communication PAC3220

Ethernet interface	Number of interfaces	2
	Version	RJ45
	Protocol	<ul style="list-style-type: none"> • Modbus TCP • Web server (HTTP) • SNMP • DHCP
	Number of simultaneous communication connections	3 Modbus TCP connections + web server
	Data rate	10 / 100 Mbit/s, autonegotiation and auto-MDX (medium-dependent interface)

Display and operator control







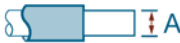

Display and operator control		
Display	Version	Monochrome, graphical LC display
	Backlighting	White, invertible display
	Service life of the LEDs	25,000 hours at 25 °C ambient temperature. To achieve a service life of at least 10 years, the backlighting should be switched on for no more than 10 % of the device operating time.
	Resolution	128 x 96 pixels
	Size W x H	74 mm x 56 mm
Keyboard	Version	4 function keys on the front, multiple assignments

Connection components: Current connection, voltage connection

Connection components: Current connection, voltage connection		
Conductor cross-section for copper cable (Cu)	Rigid	0.2 ... 6 mm ² (AWG 24 ... 10)
		
	Flexible	0.2 ... 4 mm ² (AWG 24 ... 12)
		
2 conductors (same cross-section)	Flexible with end sleeve, without plastic sleeve	0.2 ... 4 mm ² (AWG 24 ... 12)
		
	Flexible with end sleeve and plastic sleeve	0.25 ... 4 mm ² (AWG 24 ... 12)
		
2 conductors (same cross-section)	Rigid	0.2 ... 1.5 mm ² (AWG 24 ... 16)
		
	Flexible	0.2 ... 1.5 mm ² (AWG 24 ... 16)
		
2 conductors (same cross-section)	Flexible with end sleeve, without plastic sleeve	0.25 ... 0.75 mm ² (AWG 24 ... 19)
		
	Flexible with TWIN end sleeve and plastic sleeve	0.5 ... 2.5 mm ² (AWG 20 ... 14)
		
	Tightening torque	0.5 ... 0.6 Nm (4.4 ... 5.3 lb-in)

Connection components: Communication ports PAC3120

Connection components: Communication ports PAC3120

Conductor cross-section for copper cable (Cu)	Rigid	0.14 ... 1.5 mm ² (AWG 26 ... 16)
		
	Flexible	0.14 ... 1.5 mm ² (AWG 26 ... 16)
		
2 conductors (same cross-section)	Flexible with end sleeve, without plastic sleeve	0.25 ... 1 mm ² (AWG 24 ... 18)
		
	Flexible with end sleeve and plastic sleeve	0.25 ... 1.5 mm ² (AWG 24 ... 16)
		
2 conductors (same cross-section)	Rigid	0.14 ... 0.75 mm ² (AWG 26 ... 19)
		
	Flexible	0.14 ... 0.75 mm ² (AWG 26 ... 19)
		
2 conductors (same cross-section)	Flexible with end sleeve, without plastic sleeve	0.25 ... 0.5 mm ² (AWG 24 ... 20)
		
	Flexible with TWIN end sleeve and plastic sleeve	0.5 ... 1 mm ² (AWG 20 ... 18)
		
Tightening torque		0.5 ... 0.6 Nm (4.4 ... 5.3 lb-in)

Dimensions and weights

Dimensions and weights		
Type of mounting	Panel mounting to IEC 61554	
Enclosure dimensions W x H x D	96 mm x 96 mm x 56 mm	
Cutout (W x H)	92 mm +0.8 mm x 92 mm +0.8 mm	
Mounting depth (without expansion modules)	51 mm	
Permissible switching panel thickness for installation	≤ 4 mm	
Mounting position	Vertical	
Weight	Device without packaging	Approx. 325 g
	Device including packaging	Approx. 460 g

Degree of protection and protection class

Degree of protection and protection class		
Protection class	Protection class II when installed	
Degree of protection according to IEC 60529	Device front panel	IP65
	Device rear panel	IP20

If a higher degree of protection is required for a specific application, the customer must take suitable measures.

Ambient conditions

The device is suitable for switch panel mounting in accordance with IEC 61554. The device may only be operated within enclosed dry rooms.

Ambient conditions		
Temperature range	Ambient temperature during operation	-25 ... +55 °C (K55)
	Ambient temperature during transportation and storage	-25 ... +70 °C
Relative humidity		< 75 % RH
Installation altitude above sea level		Max. 2000 m
Pollution degree		2
Environmental tests		<ul style="list-style-type: none"> • EN 60068-2-27 • EN 60068-2-6 • EN 60068-3-3

Relative humidity in relation to ambient temperature



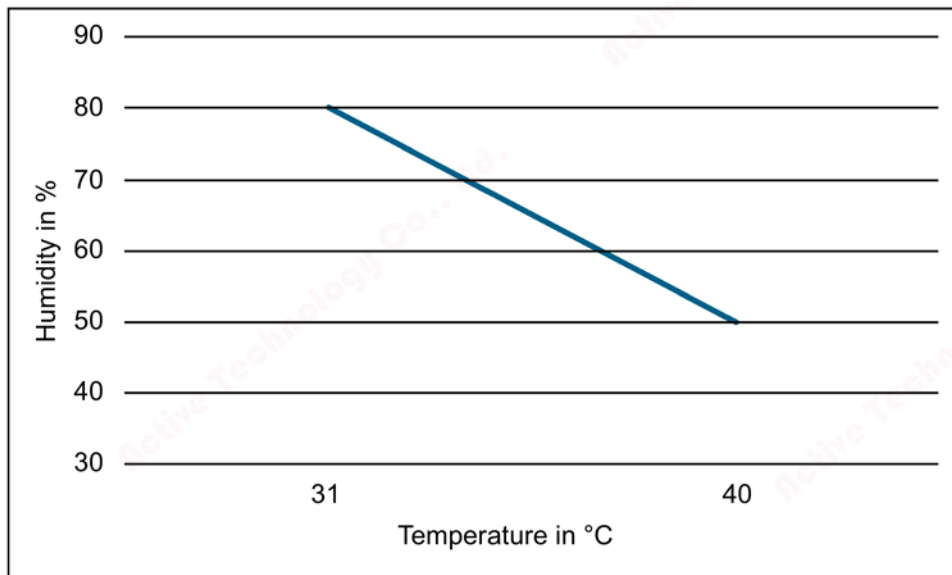



The maximum relative humidity is 80 % at temperatures up to 31 °C, decreasing linearly down to 50 % relative humidity at 40 °C.



Electromagnetic compatibility

Electromagnetic compatibility	
Emitted interference	EN 61323-1 (Class B)
Interference immunity	<ul style="list-style-type: none"> EN 61326-1 (Table 2: For use in an industrial electromagnetic environment) <ul style="list-style-type: none"> EN 61000-6-2

Approvals

Symbol	Approval
	CE conformity The applied directives and standards can be found in the EU Declaration of Conformity.
	CT verification marking (Russia) (available soon) Products with this marking have obtained a metrological certificate. This confirms conformity with the legal provisions pertaining to technical regulation in the Russian Federation.
	Approvals for Australia and New Zealand RCM (Regulatory Compliance Mark)
	Approvals for Eurasian Customs Union (valid in Russia, Belarus, Kazakhstan, Kyrgyzstan and Armenia)
	(available soon) Products with this symbol meet both UL and Canadian requirements.
	(available soon) KCC test symbol (Korea)

You can download the relevant certificates from the Siemens Support website (<https://support.industry.siemens.com>):

- PAC3120 (<https://support.industry.siemens.com/cs/ww/de/ps/7KM3120-1BA01-1EA0/cert>)
- PAC3220 (<https://support.industry.siemens.com/cs/ww/de/ps/7KM3220-1BA01-1EA0/cert>)

10.2 Labeling

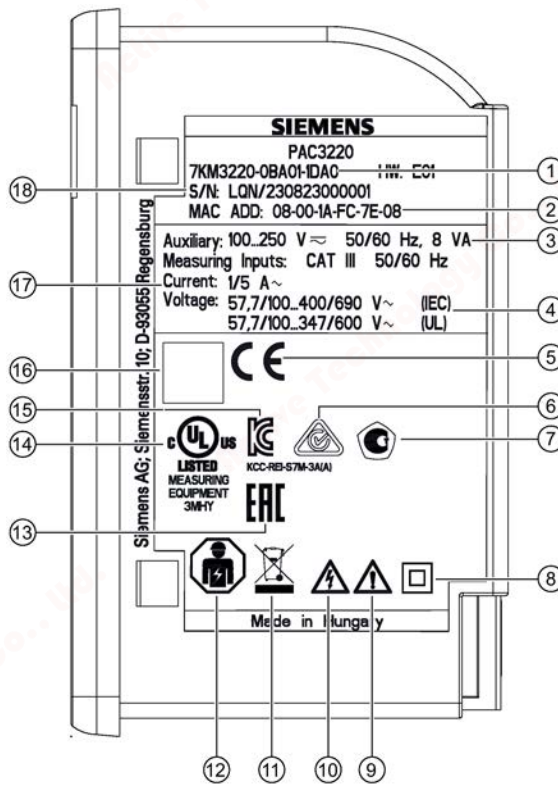













Figure 10-1 View of a typical rating plate illustrated by the example of a PAC3220 (230 V) device

Table 10- 1 Legend

Item	Symbol, label	Explanation
①	-	Article number
②	-	MAC address
③	-	Device supply voltage
④	-	Data about measuring inputs for voltage
⑤		CE marking (European Union)
⑥		RCM test symbol (Australia and New Zealand)
⑦		CT verification marking (Russia) Products with this marking have obtained a metrological certificate. This confirms conformity with the legal provisions pertaining to technical regulation in the Russian Federation.
⑧		Protective insulation - class II device
⑨		General warning symbol
⑩		Risk of electric shock
⑪		The device must not be disposed of with general domestic waste.
⑫		Electrical installation and maintenance by qualified personnel only
⑬		EAC marking (Eurasian Economic Union)
⑭		Products with this mark comply with both the Canadian (CSA) and the American (UL) requirements.
⑮		KCC test symbol (Korea)
⑯	-	2D code (serial number of the device)
⑰	-	Data about measuring inputs for current
⑱	-	Serial number of the device

Dimensional drawings

Panel cutout

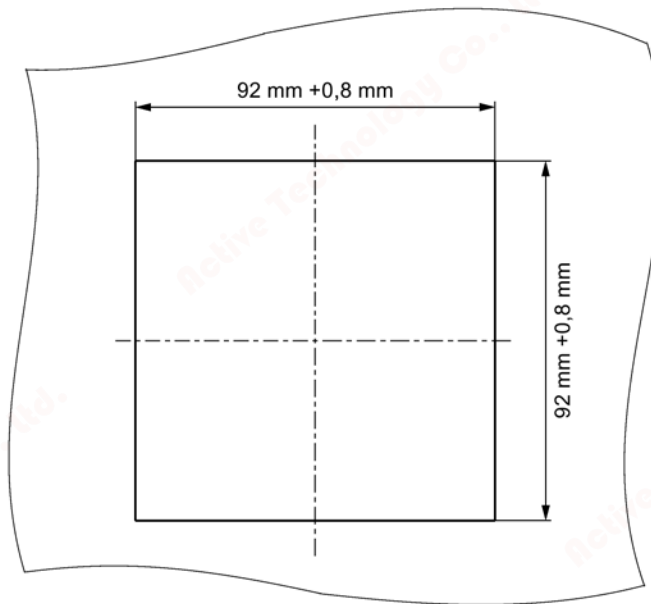

Figure 11-1 Panel cutout

Frame dimensions

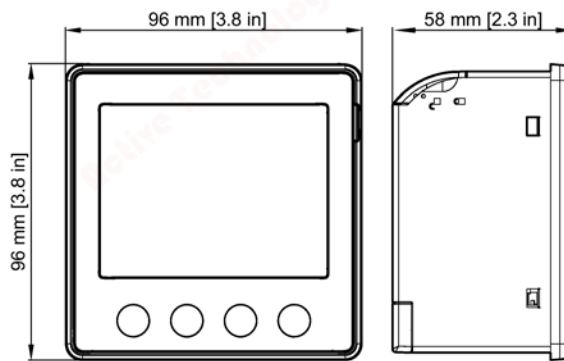
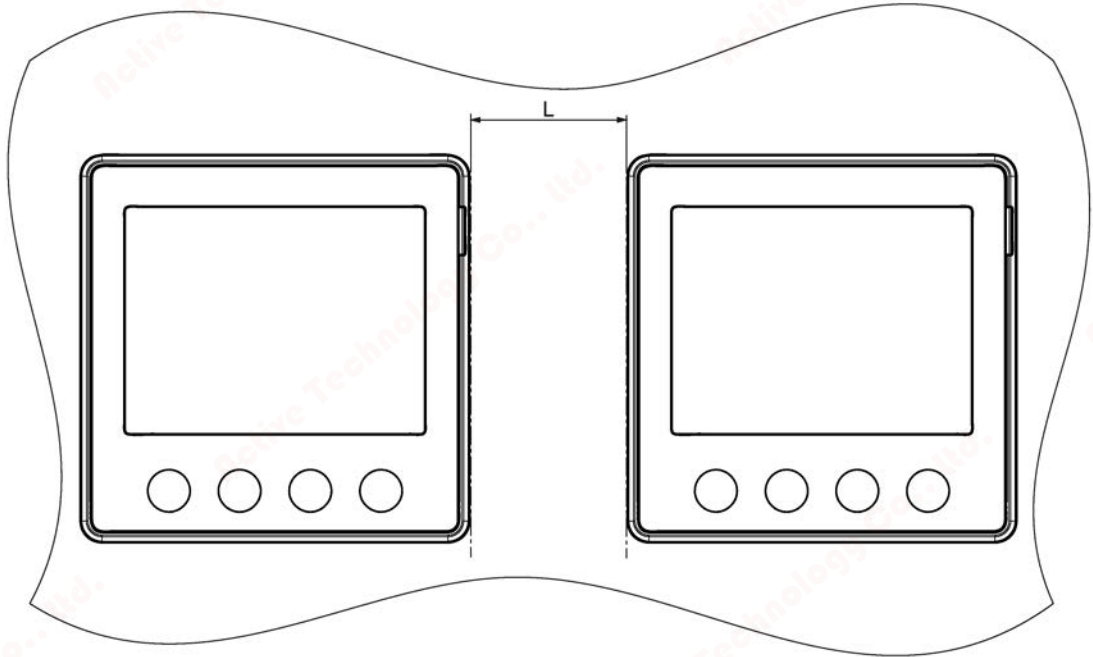

Figure 11-2 Frame dimensions

Clearance measurements



L = 30 mm if mounting brackets supplied with the device are used

L = 5 mm if compact brackets available to order as separate components are used (article number: 7KM9900-0GA00-0AA0)

Appendix

A.1 Modbus

Detailed information about Modbus can be found at the Modbus website (<http://www.modbus.org>).

A.1.1 Function codes

Function codes control the data exchange. To do this, a function code tells the slave which action it is to take.

If an error occurs, the MSB bit is set in the response frame in the FC byte.

Supported Modbus function codes

Table A- 1 Supported Modbus function codes

FC	Function in accordance with Modbus specification
0 x 01	Read Coils
0 x 02	Read Discrete Inputs
0 x 03	Read Holding Registers
0 x 04	Read Input Registers
0 x 05	Write Single Coil
0 x 06	Write Single Register
0 x 0F	Write Multiple Coils
0 x 10	Write Multiple Registers
0 x 2B	Read Device Identification
0 x 14	Read File Record (for demand values)

A.1.2 Exception codes

Overview

Table A- 2 Modbus exception codes

Exception codes	Name	Meaning	Remedy
01	Illegal Function	Illegal function: <ul style="list-style-type: none"> The function code in the request is not a permissible action for the slave. The slave is in a status in which it cannot process a request of this type. This is the case, for example, if it has not yet been configured and is requested to return register values. 	Check which function codes are supported.
02	Illegal Data Address	Illegal data address: This address is not permissible for the slave. This is the case, for example, if the combination of start offset and transfer length is invalid.	Check the offset and the number of registers.
03	Illegal Data Value	Illegal data value: The request contains a data value that is not permissible for the slave. This indicates an error in the remaining structure of a complex request, e.g. an incorrect data length.	Check that the specified offset and the specified data length in the command are correct.
04	Slave Device Failure	Error in processing the data: An indefinite error occurred when the slave attempted to execute the requested action.	Check that the specified offset and the specified data length in the command are correct.
F0	Write Protection ON	The action has been rejected because the write protection is set.	Deactivate the write protection.

A.1.3 Modbus measured variables with the function codes 0x03 and 0x04

Addressing the measured variables

You can use the Modbus function codes 0x03 and 0x04 on all the measured variables listed below.

Note

Error in the case of inconsistent access to measured values

Please ensure the start offset of the register is correct for **read access operations**.

Please ensure the start offset and the number of registers are correct for **write access operations**.

If a value consists of two registers, a read command applied in the second register, for example, will generate an error code. The device will also output an error code if, for example, a write operation ends in the middle of a multi-register value.

Table A- 3 Meaning of the abbreviations in the "Access" column of the table headed "Available measured variables" below

Abbreviation	Meaning
R	Read; read access
W	Write; write access
RW	Read Write; read and write access

Table A- 4 Available measured variables

Offset	Number of registers	Name	Format	Unit	Value range	Access
1	2	Voltage L1-N	Float	V	-	R
3	2	Voltage L2-N	Float	V	-	R
5	2	Voltage L3-N	Float	V	-	R
7	2	Voltage L1-L2	Float	V	-	R
9	2	Voltage L2-L3	Float	V	-	R
11	2	Voltage L3-L1	Float	V	-	R
13	2	Current L1	Float	A	-	R
15	2	Current L2	Float	A	-	R
17	2	Current L3	Float	A	-	R
19	2	Apparent power L1	Float	VA	-	R
21	2	Apparent power L2	Float	VA	-	R
23	2	Apparent power L3	Float	VA	-	R
25	2	Active power L1	Float	W	-	R
27	2	Active power L2	Float	W	-	R

Offset	Number of registers	Name	Format	Unit	Value range	Access
29	2	Active power L3	Float	W	–	R
31	2	Reactive power L1 (VAR1)	Float	var	–	R
33	2	Reactive power L1 (VAR1)	Float	var	–	R
35	2	Reactive power L1 (VAR1)	Float	var	–	R
37	2	Power factor L1	Float	–	0 ... 1	R
39	2	Power factor L2	Float	–	0 ... 1	R
41	2	Power factor L3	Float	–	0 ... 1	R
43	2	THD-R voltage L1	Float	%	0 ... 100	R
45	2	THD-R voltage L2	Float	%	0 ... 100	R
47	2	THD-R voltage L3	Float	%	0 ... 100	R
49	2	THD-R current L1	Float	%	0 ... 100	R
51	2	THD-R current L2	Float	%	0 ... 100	R
53	2	THD-R current L3	Float	%	0 ... 100	R
55	2	Frequency	Float	Hz	45 ... 65	R
57	2	Average voltage UL-N	Float	V	–	R
59	2	Average voltage UL-L	Float	V	–	R
61	2	Average current	Float	A	–	R
63	2	Total apparent power	Float	VA	–	R
65	2	Total active power	Float	W	–	R
67	2	Total reactive power	Float	var	–	R
69	2	Total power factor	Float	–	–	R
71	2	Amplitude unbalance voltage	Float	%	0 ... 100	R
73	2	Amplitude unbalance current	Float	%	0 ... 200	R
75	2	Maximum voltage L1-N	Float	V	–	R
77	2	Maximum voltage L2-N	Float	V	–	R
79	2	Maximum voltage L3-N	Float	V	–	R
81	2	Maximum voltage L1-L2	Float	V	–	R
83	2	Maximum voltage L2-L1	Float	V	–	R
85	2	Maximum voltage L3-L1	Float	V	–	R
87	2	Maximum current L1	Float	A	–	R
89	2	Maximum current L2	Float	A	–	R
91	2	Maximum current L3	Float	A	–	R
93	2	Maximum apparent power L1	Float	VA	–	R
95	2	Maximum apparent power L2	Float	VA	–	R
97	2	Maximum apparent power L3	Float	VA	–	R
99	2	Maximum active power L1	Float	W	–	R
101	2	Maximum active power L2	Float	W	–	R
103	2	Maximum active power L3	Float	W	–	R
105	2	Maximum reactive power L1 (VARn)	Float	var	–	R
107	2	Maximum reactive power L1 (VARn)	Float	var	–	R

Offset	Number of registers	Name	Format	Unit	Value range	Access
109	2	Maximum reactive power L1 (VARn)	Float	var	-	R
111	2	Maximum power factor L1	Float	-	0 ... 1	R
113	2	Maximum power factor L2	Float	-	0 ... 1	R
115	2	Maximum power factor L3	Float	-	0 ... 1	R
117	2	Maximum THD-R voltage L1-L2	Float	%	0 ... 100	R
119	2	Maximum THD-R voltage L2-L3	Float	%	0 ... 100	R
121	2	Maximum THD-R voltage L3-L1	Float	%	0 ... 100	R
123	2	Maximum THD-R current L1	Float	%	0 ... 100	R
125	2	Maximum THD-R current L2	Float	%	0 ... 100	R
127	2	Maximum THD-R current L3	Float	%	0 ... 100	R
129	2	Maximum frequency	Float	-	45 ... 65	R
131	2	Maximum average voltage UL-N	Float	V	-	R
133	2	Maximum average voltage UL-L	Float	V	-	R
135	2	Maximum average current	Float	A	-	R
137	2	Maximum total apparent power	Float	VA	-	R
139	2	Maximum total active power	Float	W	-	R
141	2	Maximum total reactive power (VARn)	Float	var	-	R
143	2	Maximum total power factor	Float	-	-	R
145	2	Minimum voltage L1-N	Float	V	-	R
147	2	Minimum voltage L2-N	Float	V	-	R
149	2	Minimum voltage L3-N	Float	V	-	R
151	2	Minimum voltage L1-L2	Float	V	-	R
153	2	Minimum voltage L2-L1	Float	V	-	R
155	2	Minimum voltage L3-L1	Float	V	-	R
157	2	Minimum current L1	Float	A	-	R
159	2	Minimum current L2	Float	A	-	R
161	2	Minimum current L3	Float	A	-	R
163	2	Minimum apparent power L1	Float	VA	-	R
165	2	Minimum apparent power L2	Float	VA	-	R
167	2	Minimum apparent power L3	Float	VA	-	R
169	2	Minimum active power L1	Float	W	-	R
171	2	Minimum active power L2	Float	W	-	R
173	2	Minimum active power L3	Float	W	-	R
175	2	Minimum reactive power L1 (VARn)	Float	var	-	R
177	2	Minimum reactive power L1 (VARn)	Float	var	-	R
179	2	Minimum reactive power L1 (VARn)	Float	var	-	R
181	2	Minimum power factor L1	Float	-	0 ... 1	R

Offset	Number of registers	Name	Format	Unit	Value range	Access
183	2	Minimum power factor L2	Float	–	0 ... 1	R
185	2	Minimum power factor L3	Float	–	0 ... 1	R
187	2	Minimum frequency	Float	Hz	45 ... 65	R
189	2	Minimum average voltage UL	Float	V	–	R
191	2	Minimum average voltage UL-L	Float	V	–	R
193	2	Minimum average current	Float	A	–	R
195	2	Minimum total apparent power	Float	VA	–	R
197	2	Minimum total active power	Float	W	–	R
199	2	Minimum total reactive power (VARn)	Float	var	–	R
201	2	Minimum total power factor	Float	var	–	R
203	2	Limit violations	Unsigned long	–	Byte3 Bit0 Limit 0 Byte3 Bit1 Limit 1 Byte3 Bit2 Limit 2 Byte3 Bit3 Limit 3 Byte3 Bit4 Limit 4 Byte3 Bit5 Limit 5 Byte0 Bit0 Limit comb.	R
205	2	PMD diagnostics and status	Unsigned long	–	Byte0 global state Byte1 local state Byte2 global diag. Byte3 local diag.	R
207	2	Digital outputs status	Unsigned long	–	Byte3 Bit0 Output 0.0 Byte3 Bit1 Output 0.1	R
209	2	Digital inputs status	Unsigned long	–	Byte3 Bit0 Input 0.0 Byte3 Bit1 Input 0.1	R
211	2	Active tariff	Unsigned long	–	0 = Tariff 1 1 = Tariff 2	R
213	2	Operating hours counter	Unsigned long	s	0 ... 999999999	RW
215	2	Counter (configurable)	Unsigned long	–	0 ... 999999999	RW
217	2	Counter basic parameter changes	Unsigned long	–	–	R
219	2	Counter all parameter changes	Unsigned long	–	–	R
221	2	Counter limit value changes	Float	–	–	R
223	2	Current N	Float	A	–	R
225	2	Maximum current N	Float	A	–	R
227	2	Minimum current N	Float	A	–	R
231	2	Configurable energy counter	Float	kWh, kvarh	–	R
233	2	Status digital outputs module 1	Unsigned long	–	Byte3 Bit0 Output 4.0 Byte3 Bit0 Output 4.1	R

Offset	Number of registers	Name	Format	Unit	Value range	Access
235	2	Status digital inputs module 1	Unsigned long	–	Byte3 Bit0 Input 4.0 Byte3 Bit1 Input 4.1 Byte3 Bit2 Input 4.2 Byte3 Bit3 Input 4.3	R
237	2	Status digital outputs module 2	Unsigned long	–	Byte3 Bit0 Output 8.0 Byte3 Bit0 Output 8.1	R
239	2	Status digital inputs module 2	Unsigned long	–	Byte3 Bit0 Input 8.0 Byte3 Bit1 Input 8.1 Byte3 Bit2 Input 8.2 Byte3 Bit3 Input 8.3	R
501	2	Cumulated average active power import	Float	W	–	R
503	2	Cumulated average reactive power import	Float	var	–	R
505	2	Cumulated average active power export	Float	W	–	R
507	2	Cumulated average reactive power export	Float	var	–	R
509	2	Maximum active power reading during demand period	Float	W	–	R
511	2	Minimum active power reading during demand period	Float	W	–	R
513	2	Maximum reactive power reading during demand period	Float	var	–	R
515	2	Minimum reactive power reading during demand period	Float	var	–	R
517	2	Length of the current demand period	Unsigned long	s	–	R
519	2	Time since start of current demand period	Unsigned long	s	–	R
799	2	Date/time	Unix_ts	–	–	RW
801	4	Total active energy import tariff 1	Double	Wh	Overflow 1.0e+12	RW
805	4	Total active energy import tariff 2	Double	Wh	Overflow 1.0e+12	RW
809	4	Total active energy export tariff 1	Double	varh	Overflow 1.0e+12	RW
813	4	Total active energy export tariff 2	Double	varh	Overflow 1.0e+12	RW
817	4	Total reactive energy import tariff 1	Double	Wh	Overflow 1.0e+12	RW
821	4	Total reactive energy import tariff 2	Double	Wh	Overflow 1.0e+12	RW
825	4	Total reactive energy export tariff 1	Double	varh	Overflow 1.0e+12	RW
829	4	Total reactive energy export tariff 2	Double	varh	Overflow 1.0e+12	RW
833	4	Total apparent energy tariff 1	Double	VAh	Overflow 1.0e+12	RW
837	4	Total apparent energy tariff 2	Double	VAh	Overflow 1.0e+12	RW

Offset	Number of registers	Name	Format	Unit	Value range	Access
841	4	L1 active energy import tariff 1	Double	Wh	Overflow 1.0e+12	RW
845	4	L1 active energy import tariff 2	Double	Wh	Overflow 1.0e+12	RW
849	4	L1 active energy export tariff 1	Double	varh	Overflow 1.0e+12	RW
853	4	L1 active energy export tariff 2	Double	varh	Overflow 1.0e+12	RW
857	4	L1 reactive energy import tariff 1	Double	Wh	Overflow 1.0e+12	RW
861	4	L1 reactive energy import tariff 2	Double	Wh	Overflow 1.0e+12	RW
865	4	L1 reactive energy export tariff 1	Double	varh	Overflow 1.0e+12	RW
869	4	L1 reactive energy export tariff 2	Double	varh	Overflow 1.0e+12	RW
873	4	L1 apparent energy tariff 1	Double	VAh	Overflow 1.0e+12	RW
877	4	L1 apparent energy tariff 2	Double	VAh	Overflow 1.0e+12	RW
881	4	L2 active energy import tariff 1	Double	Wh	Overflow 1.0e+12	RW
885	4	L2 active energy import tariff 2	Double	Wh	Overflow 1.0e+12	RW
889	4	L2 active energy export tariff 1	Double	varh	Overflow 1.0e+12	RW
893	4	L2 active energy export tariff 2	Double	varh	Overflow 1.0e+12	RW
897	4	L2 reactive energy import tariff 1	Double	Wh	Overflow 1.0e+12	RW
901	4	L2 reactive energy import tariff 2	Double	Wh	Overflow 1.0e+12	RW
905	4	L2 reactive energy export tariff 1	Double	varh	Overflow 1.0e+12	RW
909	4	L2 reactive energy export tariff 2	Double	varh	Overflow 1.0e+12	RW
913	4	L2 apparent energy tariff 1	Double	VAh	Overflow 1.0e+12	RW
917	4	L2 apparent energy tariff 2	Double	VAh	Overflow 1.0e+12	RW
921	4	L3 active energy import tariff 1	Double	Wh	Overflow 1.0e+12	RW
925	4	L3 active energy import tariff 2	Double	Wh	Overflow 1.0e+12	RW
929	4	L3 active energy export tariff 1	Double	varh	Overflow 1.0e+12	RW
933	4	L3 active energy export tariff 2	Double	varh	Overflow 1.0e+12	RW
937	4	L3 reactive energy import tariff 1	Double	Wh	Overflow 1.0e+12	RW
941	4	L3 reactive energy import tariff 2	Double	Wh	Overflow 1.0e+12	RW
945	4	L3 reactive energy export tariff 1	Double	varh	Overflow 1.0e+12	RW
949	4	L3 reactive energy export tariff 2	Double	varh	Overflow 1.0e+12	RW
953	4	L3 apparent energy tariff 1	Double	VAh	Overflow 1.0e+12	RW
957	4	L3 apparent energy tariff 2	Double	VAh	Overflow 1.0e+12	RW

A.1.4 Structure - Digital input status and digital output status with the function codes 0x03 and 0x04

The following are available via Modbus:

- "Digital Inputs Status"
- "Digital Outputs Status"

Table A- 5 Structure - status of the digital inputs (Modbus offset 209) and digital outputs (Modbus offset 207)

Name	Length	Status	Byte	Bit	Bit mask	Access
Digital outputs status	32 bits	DO 0.0	3	0	0x00000001	R
Digital outputs status	32 bits	DO 0.1	3	1	0x00000010	R
Digital inputs status	32 bits	DI 0.0	3	0	0x00000001	R
Digital inputs status	32 bits	DI 0.1	3	1	0x00000010	R

Table A- 6 Structure - status of the digital inputs (Modbus offset 235) and digital outputs (Modbus offset 233) for a PAC 4DI/2DO expansion module at slot MOD 1 (PAC3220 only)

Name	Length	Status	Byte	Bit	Bit mask	Access
Digital outputs status	32 bits	DO 4.0	3	0	0x00000001	R
Digital outputs status	32 bits	DO 4.1	3	1	0x00000010	R
Digital inputs status	32 bits	DI 4.0	3	0	0x00000001	R
Digital inputs status	32 bits	DI 4.1	3	1	0x00000010	R
Digital inputs status	32 bits	DI 4.2	3	2	0x00000100	R
Digital inputs status	32 bits	DI 4.3	3	3	0x00001000	R

Table A- 7 Structure - status of the digital inputs (Modbus offset 239) and digital outputs (Modbus offset 237) for a PAC 4DI/2DO expansion module at slot MOD 2 (PAC3220 only)

Name	Length	Status	Byte	Bit	Bit mask	Access
Digital outputs status	32 bits	DO 8.0	3	0	0x00000001	R
Digital outputs status	32 bits	DO 8.1	3	1	0x00000010	R
Digital inputs status	32 bits	DI 8.0	3	0	0x00000001	R
Digital inputs status	32 bits	DI 8.1	3	1	0x00000010	R
Digital inputs status	32 bits	DI 8.2	3	2	0x00000100	R
Digital inputs status	32 bits	DI 8.3	3	3	0x00001000	R

A.1.5 Structure - Device diagnostics and device status with the function codes 0x03 and 0x04

Design

Table A- 8 Modbus offset 205, register 2: Structure device status and device diagnostics

Byte	Bit	Device status	Type	Bit mask	Value range	Access
0	0	No synchronization pulse	Status	0x01000000	0 = not active 1 = active	R
0	1	Device configuration menu is active	Status	0x02000000		R
0	2	Voltage overload	Status	0x04000000		R
0	3	Current overload	Status	0x08000000		R
1	1	Maximum pulse rate exceeded	Status	0x00020000		R
2	0	Relevant parameter changes ¹⁾	Stored	0x00000100		R
2	2	Maximum pulse rate exceeded ¹⁾	Stored	0x00000400		R
2	3	Restart of the device ¹⁾	Stored	0x00000800		R
2	4	Resetting of energy counters by user ¹⁾	Stored	0x00001000	R	

¹⁾ Only these device states must be acknowledged.

A.1.6 Modbus status parameters with the function code 0x02

Status parameters

You can use the Modbus function code 0x02 on all the status parameters listed below.

Table A- 9 Status parameters

Offset	Number of registers	Name	Format	Value range	Access
0	0	Limit 0	Bit	0 = not active 1 = active	R
1	0	Limit 1	Bit		R
2	0	Limit 2	Bit		R
3	0	Limit 3	Bit		R
4	0	Limit 4	Bit		R
5	0	Limit 5	Bit		R
51	0	Limit logic	Bit		R
108	0	Bit 0 Relevant parameter changes	Bit		R
109	0	Bit 1 Upper or lower limit violation	Bit		R
110	0	Bit 2 Maximum pulse rate exceeded	Bit		R
111	0	Bit 3 Restart of the device	Bit		R
112	0	Bit 4 Resetting of energy counters by user	Bit		R
116	0	Bit 0 Module slot 1	Bit		R
117	0	Bit 1 Maximum pulse rate exceeded	Bit		R
118	0	Bit 2 Module slot 2	Bit		R
123	0	Bit 7 Waiting for user input	Bit		R
124	0	Bit 0 No synchronization pulse	Bit		R
125	0	Bit 1 Device configuration menu is active	Bit		R
126	0	Bit 2 Voltage overload	Bit		R
127	0	Bit 3 Current overload	Bit		R
128	0	Bit 4 Date/time of device not secure	Bit		R
129	0	Bit 5 Device update in progress	Bit	R	
130	0	Bit 6 Hardware write protection is active	Bit	R	
131	0	Bit 7 Modbus communication protected by password	Bit	R	
200	0	Digital input 0.0	Bit		R
201	0	Digital input 0.1	Bit		R
232	0	Digital input 4.0 ¹⁾	Bit		R
233	0	Digital input 4.1 ¹⁾	Bit		R
234	0	Digital input 4.2 ¹⁾	Bit		R
235	0	Digital input 4.3 ¹⁾	Bit		R
264	0	Digital input 8.0 ¹⁾	Bit		R
265	0	Digital input 8.1 ¹⁾	Bit		R
266	0	Digital input 8.2 ¹⁾	Bit		R

Appendix

A.1 Modbus

Offset	Number of registers	Name	Format	Value range	Access
267	0	Digital input 8.3 ¹⁾	Bit		R
400	0	Digital output 0.0	Bit		R
401	0	Digital output 0.1	Bit		R
432	0	Digital output 4.0 ¹⁾	Bit		R
433	0	Digital output 4.1 ¹⁾	Bit		R
464	0	Digital output 8.0 ¹⁾	Bit		R
465	0	Digital output 8.1 ¹⁾	Bit		R

¹⁾ Applies only to PAC3220 and 4DI/2DO expansion module

A.1.7 Modbus settings with the function codes 0x03, 0x04 and 0x10

Addressing the settings

You can use the Modbus function codes 0x03 and 0x04 for read access operations and 0x10 for write access operations on all the setting parameters listed below.

Table A- 10 Setting parameters

Offset	Number of registers	Name	Unit	Format	Value range	Access
50001	2	Connection type	–	Unsigned long	0 ... 4 0 = 3P4W 1 = 3P3W 2 = 3P4WB 3 = 3P3WB 4 = 1P2W	RW
50003	2	Voltage measurement using voltage transformer yes/no	–	Unsigned long	0 ... 1 0 = No 1 = Yes	RW
50005	2	Primary voltage	V	Unsigned long	1 ... 999999	RW
50007	2	Secondary voltage	V	Unsigned long	1 ... 480	RW
50011	2	Primary current	A	Unsigned long	1 ... 99999	RW
50013	2	Secondary current	A	Unsigned long	1 ... 5	RW
50019	2	Zero point suppression level	%	Float	0.0 ... 10.0	RW
50021	2	Demand period	Min.	Unsigned long	1 ... 60	RW
50023	2	Synchronization	–	Unsigned long	0 ... 2 0 = No synchronization 1 = Synchronization via bus 2 = Synchronization via digital input	RW
50025	2	DI 0.0 Type of use	–	Unsigned long	0 ... 3 0 = No action 1 = Pulse interface 2 = Switching on/off peak 3 = Synchronization	RW
50029	2	DI 0.0 Index	–	Unsigned long	0 ... 1 0 = kWh 1 = kvarh	RW
50031	2	DI 0.0 Pulses per unit	–	Unsigned long	1 ... 4000	RW
50033	2	DO 0.0 Vector group assignment	–	Unsigned long	0 ... 99	RW

Offset	Number of registers	Name	Unit	Format	Value range	Access
50035	2	DO 0.0 Type of use	–	Unsigned long	0 ... 5 0 = No action 1 = Device active 2 = Switching output 3 = Direct. of rotation 4 = Limit value 5 = Pulse output	RW
50037	2	DO 0.0 Limit value	–	Unsigned long	0 ... 6 0 = Comb. limit 1 = Limit0 2 = Limit1 3 = Limit2 4 = Limit3 5 = Limit4 6 = Limit5	RW
50041	2	DO 0.0 Index	–	Unsigned long	0 ... 3 0 = Import kWh 1 = Export kWh 2 = Import kvarh 3 = Export kvarh	RW
50043	2	DO 0.0 Pulses per kWh/kvarh	–	Unsigned long	1 ... 4000	RW
50045	2	DO 0.0 Pulse length	–	Unsigned long	30 ... 500	RW
50047	2	Dialog language	–	Unsigned long	0 ... 1 0 = German 1 = English	RW
50049	2	Phase labels EU/US	–	Unsigned long	0 ... 1 0 = IEC 1 = US	RW
50051	2	Configurable counter source	–	Unsigned long	0 ... 8 0 = Digital input 1 = Digital output 2 = Comb. limit 3 = Limit0 4 = Limit1 5 = Limit2 6 = Limit3 7 = Limit4 8 = Limit5	RW
50053	2	Display refresh cycle	–	Unsigned long	Byte 0 → 0 Byte 1 → 0 Byte 2 → Port 0 ... 11 Byte 3 → Port bit 0 ... 7	RW
50055	2	Display contrast	–	Unsigned long	0 ... 10	RW
50057	2	Display backlight level	%	Unsigned long	0 ... 3	RW
50059	2	Display backlight dimmed	%	Unsigned long	0 ... 3	RW

Offset	Number of registers	Name	Unit	Format	Value range	Access
50061	2	Display time until dimmed	min	Unsigned long	0 ... 99	RW
50063	2	Limit 0 ON/OFF	-	Unsigned long	0 ... 1 0 = Off 1 = On	RW
50065	2	Limit 0 Hysteresis	%	Float	0.0 ... 20.0	RW
50067	2	Limit 0 Delay	s	Unsigned long	0 ... 10	RW
50069	2	Limit 0 Index (NO/AND/OR)	-	Unsigned long	0 ... 2 0 = NO 1 = AND 2 = OR	RW
50071	2	Limit 0 Index of data list	-	Unsigned long	0 ... 36	RW
50073	2	Limit 0 Source	-	Float	-	RW
50075	2	Limit 0 Type \geq / $<$	-	Unsigned long	0 ... 1 0 = Greater than 1 = Smaller than	RW
50077	2	Limit 1 ON/OFF	-	Unsigned long	0 ... 1 0 = Off 1 = On	RW
50079	2	Limit 1 Hysteresis	%	Float	0.0 ... 20.0	RW
50081	2	Limit 1 Delay	s	Unsigned long	0 ... 10	RW
50083	2	Limit 1 Index (NO/AND/OR)	-	Unsigned long	0 ... 2 0 = NO 1 = AND 2 = OR	RW
50085	2	Limit 1 Index of data list	-	Unsigned long	0 ... 36	RW
50087	2	Limit 1 Source	-	Float	-	RW
50089	2	Limit 1 Type \geq / $<$	-	Unsigned long	0 ... 1 0 = Greater than 1 = Smaller than	RW
50091	2	Limit 2 ON/OFF	-	Unsigned long	0 ... 1 0 = Off 1 = On	RW
50093	2	Limit 2 Hysteresis	%	Float	0.0 ... 20.0	RW
50095	2	Limit 2 Delay	s	Unsigned long	0 ... 10	RW
50097	2	Limit 2 Index (NO/AND/OR)	-	Unsigned long	0 ... 2 0 = NO 1 = AND 2 = OR	RW
50099	2	Limit 2 Index of data list	-	Unsigned long	0 ... 36	RW
50101	2	Limit 2 Source	-	Float	-	RW

Offset	Number of registers	Name	Unit	Format	Value range	Access
50103	2	Limit 2 Type \geq / $<$	–	Unsigned long	0 ... 1 0 = Greater than 1 = Smaller than	RW
50105	2	Limit 3 ON/OFF	–	Unsigned long	0 ... 1 0 = Off 1 = On	RW
50107	2	Limit 3 Hysteresis	%	Float	0.0 ... 20.0	RW
50109	2	Limit 3 Delay	s	Unsigned long	0 ... 10	RW
50111	2	Limit 3 Index (NO/AND/OR)	–	Unsigned long	0 ... 2 0 = NO 1 = AND 2 = OR	RW
50113	2	Limit 3 Index of data list	–	Unsigned long	0 ... 36	RW
50115	2	Limit 3 Source	–	Float	–	RW
50117	2	Limit 3 Type \geq / $<$	–	Unsigned long	0 ... 1 0 = Greater than 1 = Smaller than	RW
50119	2	Limit 4 ON/OFF	–	Unsigned long	0 ... 1 0 = Off 1 = On	RW
50121	2	Limit 4 Hysteresis	%	Float	0.0 ... 20.0	RW
50123	2	Limit 4 Delay	s	Unsigned long	0 ... 10	RW
50125	2	Limit 4 Index (NO/AND/OR)	–	Unsigned long	0 ... 2 0 = NO 1 = AND 2 = OR	RW
50127	2	Limit 4 Index of data list	–	Unsigned long	0 ... 36	RW
50129	2	Limit 4 Source	–	Float	–	RW
50131	2	Limit 4 Type \geq / $<$	–	Unsigned long	0 ... 1 0 = Greater than 1 = Smaller than	RW
50133	2	Limit 5 ON/OFF	–	Unsigned long	0 ... 1 0 = Off 1 = On	RW
50135	2	Limit 5 Hysteresis	%	Float	0.0 ... 20.0	RW
50137	2	Limit 5 Delay	s	Unsigned long	0 ... 10	RW
50139	2	Limit 5 Index (NO/AND/OR)	–	Unsigned long	0 ... 2 0 = NO 1 = AND 2 = OR	RW
50141	2	Limit 5 Index of data list	–	Unsigned long	0 ... 36	RW
50143	2	Limit 5 Source	–	Float	0 ... N	RW

Offset	Number of registers	Name	Unit	Format	Value range	Access
50145	2	Limit 5 Type \geq / $<$	–	Unsigned long	0 ... 1 0 = Greater than 1 = Smaller than	RW
50147	2	DO 0.0 Timeout	–	Unsigned long	0.1 ... 18000 Digital output remote timeout 1 ... 18000 s, 0 = Disables timeout (default)	RW
50149	2	Default menu No.	–	Unsigned long	DISPLAYED MENU NUMBER: 1 ... 29: Only existing menus are accepted 1 = MEAS_VLN 2 = MEAS_VLL 3 = MEAS_I 4 = MEAS_S 5 = MEAS_P 6 = MEAS_Q 7 = MEAS_SPQ 8 = MEAS_PF 9 = MEAS_COS 10 = MEAS_F 11 = EAS_IMBALM 12 = MEAS_THDI 13 = MEAS_THDU 14 = MEAS_THDULL 15 = MEAS_WORK_S 16 = MEAS_WORK_P 17 = MEAS_WORK_Q 18 = MEAS_COUNTER 19 = MEAS_WORKHOUR 20 = MEAS_MODUL1 (valid only if measuring module (e.g. I-N module) plugged in slot "Mod1") 21 = MEAS_MODUL2 (valid only if measuring module (e.g. I-N module) plugged in slot "Mod2")	RW
50151	2	Timeout for return to default menu	–	Unsigned long	0 ... 3600 s 0 = No timeout 10 ... 3600 s 1 s \leq timeout < 10 s: timeout is set to 10 s	RW
50231	2	Date format	–	Unsigned long	0 ... 2 0 = dd.mm.yyyy 1 = mm/dd/yy 2 = yyyy-mm-dd	RW
50233	2	Daylight saving	–	Unsigned long	0 ... 3 0 = No 1 = Auto EU 2 = Auto US 3 = Daylight saving table	RW

Appendix

A.1 Modbus

Offset	Number of registers	Name	Unit	Format	Value range	Access
50235	2	Time zone	Min.	Long	MODULO(30)==0	RW
50237	2	DO 0.0 Pulse divider	-	Unsigned long	0 ... 3 0 = 1 kWh 1 = 10 kWh 2 = 100 kWh 3 = 1000 kWh	RW
50239	2	DI 0.0 Pulse divider	-	Unsigned long	0 ... 3 0 = 1 kWh 1 = 10 kWh 2 = 100 kWh 3 = 1000 kWh	RW
50243	2	Current direction L1 yes/no	-	Unsigned long	0 ... 1 0 = No 1 = Yes	RW
50245	2	Current direction L2 yes/no	-	Unsigned long	0 ... 1 0 = No 1 = Yes	RW
50247	2	Current direction L3 yes/no	-	Unsigned long	0 ... 1 0 = No 1 = Yes	RW
51199	1	DI 0.0 Type of use	-	Unsigned short	0 ... 3 0 = No action 1 = Pulse interface 2 = Switching on/off peak 3 = Synchronization	RW
51201	1	DI 0.0 Index	-	Unsigned short	0 ... 1 0 = kWh 1 = kvarh	RW
51202	1	DI 0.0 Pulses per kWh/kvarh	-	Unsigned short	1 ... 4000	RW
51203	1	DI 0.0 Pulse divider	-	Unsigned short	-	RW
51204	1	DI 0.1 Type of use	-	Unsigned short	0 ... 3 0 = No action 1 = Pulse interface 2 = Switching on/off peak 3 = Synchronization	RW
51206	1	DI 0.1 Index	-	Unsigned short	0 ... 1 0 = kWh 1 = kvarh	RW
51207	1	DI 0.1 Pulses per kWh/kvarh	-	Unsigned short	1 ... 4000	RW
51208	1	DI 0.1 Pulse divider	-	Unsigned short	-	RW
51209	1	DI 4.0 Type of use	-	Unsigned short	0 ... 3 0 = No action 1 = Pulse interface 2 = Switching on/off peak 3 = Synchronization	RW

Offset	Number of registers	Name	Unit	Format	Value range	Access
51211	1	DI 4.0 Index	–	Unsigned short	0 ... 1 0 = kWh 1 = kvarh	RW
51212	1	DI 4.0 Pulses per kWh/kvarh	–	Unsigned short	1 ... 4000	RW
51213	1	DI 4.0 Pulse divider	–	Unsigned short	–	RW
51214	1	DI 4.1 Type of use	–	Unsigned short	0 ... 3 0 = No action 1 = Pulse interface 2 = Switching on/off peak 3 = Synchronization	RW
51216	1	DI 4.1 Index	–	Unsigned short	0 ... 1 0 = kWh 1 = kvarh	RW
51217	1	DI 4.1 Pulses per kWh/kvarh	–	Unsigned short	1 ... 4000	RW
51218	1	DI 4.1 Pulse divider	–	Unsigned short	–	RW
51219	1	DI 4.2 Type of use	–	Unsigned short	0 ... 3 0 = No action 1 = Pulse interface 2 = Switching on/off peak 3 = Synchronization	RW
51221	1	DI 4.2 Index	–	Unsigned short	0 ... 1 0 = kWh 1 = kvarh	RW
51222	1	DI 4.2 Pulses per kWh/kvarh	–	Unsigned short	1 ... 4000	RW
51223	1	DI 4.2 Pulse divider	–	Unsigned short	–	RW
51224	1	DI 4.3 Type of use	–	Unsigned short	0 ... 3 0 = No action 1 = Pulse interface 2 = Switching on/off peak 3 = Synchronization	RW
51226	1	DI 4.3 Index	–	Unsigned short	0 ... 1 0 = kWh 1 = kvarh	RW
51227	1	DI 4.3 Pulses per kWh/kvarh	–	Unsigned short	1 ... 4000	RW
51228	1	DI 4.3 Pulse divider	–	Unsigned short	–	RW
51229	1	DI 8.0 Type of use	–	Unsigned short	0 ... 3 0 = No action 1 = Pulse interface 2 = Switching on/off peak 3 = Synchronization	RW

Offset	Number of registers	Name	Unit	Format	Value range	Access
51231	1	DI 8.0 Index	–	Unsigned short	0 ... 1 0 = kWh 1 = kvarh	RW
51232	1	DI 8.0 Pulses per kWh/kvarh	–	Unsigned short	1 ... 4000	RW
51233	1	DI 8.0 Pulse divider	–	Unsigned short	–	RW
51234	1	DI 8.1 Type of use	–	Unsigned short	0 ... 3 0 = No action 1 = Pulse interface 2 = Switching on/off peak 3 = Synchronization	RW
51236	1	DI 8.1 Index	–	Unsigned short	0 ... 1 0 = kWh 1 = kvarh	RW
51237	1	DI 8.1 Pulses per kWh/kvarh	–	Unsigned short	1 ... 4000	RW
51238	1	DI 8.1 Pulse divider	–	Unsigned short	–	RW
51239	1	DI 8.2 Type of use	–	Unsigned short	0 ... 3 0 = No action 1 = Pulse interface 2 = Switching on/off peak 3 = Synchronization	RW
51241	1	DI 8.2 Index	–	Unsigned short	0 ... 1 0 = kWh 1 = kvarh	RW
51242	1	DI 8.2 Pulses per kWh/kvarh	–	Unsigned short	1 ... 4000	RW
51243	1	DI 8.2 Pulse divider	–	Unsigned short	–	RW
51244	1	DI 8.3 Type of use	–	Unsigned short	0 ... 3 0 = No action 1 = Pulse interface 2 = Switching on/off peak 3 = Synchronization	RW
51246	1	DI 8.3 Index	–	Unsigned short	0 ... 1 0 = kWh 1 = kvarh	RW
51247	1	DI 8.3 Pulses per kWh/kvarh	–	Unsigned short	1 ... 4000	RW
51248	1	DI 8.3 Pulse divider	–	Unsigned short	–	RW
51711	1	DO 0.0 Group assignment	–	Unsigned short	0 ... 99	RW

Offset	Number of registers	Name	Unit	Format	Value range	Access
51712	1	DO 0.0 Type of use	–	Unsigned short	0 ... 5 0 = No action 1 = Device active 2 = Switching output 3 = Direct. of rotation 4 = Limit value 5 = Pulse output	RW
51713	1	DO 0.0 Limit value index	–	Unsigned short	0 ... 6 0 = Comb. limit 1 = Limit0 2 = Limit1 3 = Limit2 4 = Limit3 5 = Limit4 6 = Limit5	RW
51715	1	DO 0.0 Index	–	Unsigned short	0 ... 3 0 = Import kWh 1 = Export kWh 2 = Import kvarh 3 = Export kvarh	RW
51716	1	DO 0.0 Pulses per kWh/kvarh	–	Unsigned short	1 ... 4000	RW
51717	1	DO 0.0 Pulse length	–	Unsigned short	30 ... 500	RW
51718	1	DO 0.0 Timeout	–	Unsigned short	0.1 ... 18000 Digital output remote timeout 1 ... 18000 s, 0 = Disables timeout (default)	RW
51719	1	DO 0.0 Pulse divider	–	Unsigned short	0 ... 3 0 = 1 kWh 1 = 10 kWh 2 = 100 kWh 3 = 1000 kWh	RW
51720	1	DO 0.1 Group assignment	–	Unsigned short	0 ... 99	RW
51721	1	DO 0.1 Type of use	–	Unsigned short	0 ... 5 0 = No action 1 = Device active 2 = Switching output 3 = Direction of rotation 4 = Limit value 5 = Pulse output	RW
51722	1	DO 0.1 Limit value index	–	Unsigned short	0 ... 6 0 = Comb. limit 1 = Limit0 2 = Limit1 3 = Limit2 4 = Limit3 5 = Limit4 6 = Limit5	RW

Offset	Number of registers	Name	Unit	Format	Value range	Access
51724	1	DO 0.1 Index	–	Unsigned short	0 ... 3 0 = Import kWh 1 = Export kWh 2 = Import kvarh 3 = Export kvarh	RW
51725	1	DO 0.1 Pulses per kWh/kvarh	–	Unsigned short	1 ... 4000	RW
51726	1	DO 0.1 Pulse length	–	Unsigned short	30 ... 500	RW
51727	1	DO 0.1 Timeout	–	Unsigned short	0.1 ... 18000 Digital output remote timeout 1 ... 18000 s, 0 = Disables timeout (default)	RW
51728	1	DO 0.1 Pulse divider	–	Unsigned short	0 ... 3 0 = 1 kWh 1 = 10 kWh 2 = 100 kWh 3 = 1000 kWh	RW
51729	1	DO 4.0 Group assignment	–	Unsigned short	0 ... 99	RW
51730	1	DO 4.0 Type of use	–	Unsigned short	0 ... 5 0 = No action 1 = Device active 2 = Switching output 3 = Direct. of rotation 4 = Limit value 5 = Pulse output	RW
51731	1	DO 4.0 Limit value index	–	Unsigned short	0 ... 6 0 = Comb. limit 1 = Limit0 2 = Limit1 3 = Limit2 4 = Limit3 5 = Limit4 6 = Limit5	RW
51733	1	DO 4.0 Index	–	Unsigned short	0 ... 3 0 = Import kWh 1 = Export kWh 2 = Import kvarh 3 = Export kvarh	RW
51734	1	DO 4.0 Pulses per kWh/kvarh	–	Unsigned short	1 ... 4000	RW
51735	1	DO 4.0 Pulse length	–	Unsigned short	30 ... 500	RW
51736	1	DO 4.0 Timeout	–	Unsigned short	0.1 ... 18000 Digital output remote timeout 1 ... 18000 s, 0 = Disables timeout (default)	RW

Offset	Number of registers	Name	Unit	Format	Value range	Access
51737	1	DO 4.0 Pulse divider	–	Unsigned short	0 ... 3 0 = 1 kWh 1 = 10 kWh 2 = 100 kWh 3 = 1000 kWh	RW
51738	1	DO 4.1 Group assignment	–	Unsigned short	0 ... 99	RW
51739	1	DO 4.1 Type of use	–	Unsigned short	0 ... 5 0 = No action 1 = Device active 2 = Switching output 3 = Direct. of rotation 4 = Limit value 5 = Pulse output	RW
51740	1	DO 4.1 Limit value index	–	Unsigned short	0 ... 6 0 = Comb. limit 1 = Limit0 2 = Limit1 3 = Limit2 4 = Limit3 5 = Limit4 6 = Limit5	RW
51742	1	DO 4.1 Index	–	Unsigned short	0 ... 3 0 = Import kWh 1 = Export kWh 2 = Import kvarh 3 = Export kvarh	RW
51743	1	DO 4.1 Pulses per kWh/kvarh	–	Unsigned short	1 ... 4000	RW
51744	1	DO 4.1 Pulse length	–	Unsigned short	30 ... 500	RW
51745	1	DO 4.1 Timeout	–	Unsigned short	0.1 ... 18000 Digital output remote timeout 1 ... 18000 s, 0 = Disables timeout (default)	RW
51746	1	DO 4.1 Pulse divider	–	Unsigned short	0 ... 3 0 = 1 kWh 1 = 10 kWh 2 = 100 kWh 3 = 1000 kWh	RW
51747	1	DO 8.0 Group assignment	–	Unsigned short	0 ... 99	RW
51748	1	DO 8.0 Type of use	–	Unsigned short	0 ... 5 0 = No action 1 = Device active 2 = Switching output 3 = Direct. of rotation 4 = Limit value 5 = Pulse output	RW

Offset	Number of registers	Name	Unit	Format	Value range	Access
51749	1	DO 8.0 Limit value index	–	Unsigned short	0 ... 6 0 = Comb. limit 1 = Limit0 2 = Limit1 3 = Limit2 4 = Limit3 5 = Limit4 6 = Limit5	RW
51751	1	DO 8.0 Index	–	Unsigned short	0 ... 3 0 = Import kWh 1 = Export kWh 2 = Import kvarh 3 = Export kvarh	RW
51752	1	DO 8.0 Pulses per kWh/kvarh	–	Unsigned short	1 ... 4000	RW
51753	1	DO 8.0 Pulse length	–	Unsigned short	30 ... 500	RW
51754	1	DO 8.0 Timeout	–	Unsigned short	0.1 ... 18000 Digital output remote timeout 1 ... 18000 s, 0 = Disables timeout (default)	RW
51755	1	DO 8.0 Pulse divider	–	Unsigned short	0 ... 3 0 = 1 kWh 1 = 10 kWh 2 = 100 kWh 3 = 1000 kWh	RW
51756	1	DO 8.1 Group assignment	–	Unsigned short	0 ... 99	RW
51757	1	DO 8.1 Type of use	–	Unsigned short	0 ... 5 0 = No action 1 = Device active 2 = Switching output 3 = Direct. of rotation 4 = Limit value 5 = Pulse output	RW
51758	1	DO 8.1 Limit value index	–	Unsigned short	0 ... 6 0 = Comb. limit 1 = Limit0 2 = Limit1 3 = Limit2 4 = Limit3 5 = Limit4 6 = Limit5	RW
51760	1	DO 8.1 Index	–	Unsigned short	0 ... 3 0 = Import kWh 1 = Export kWh 2 = Import kvarh 3 = Export kvarh	RW
51761	1	DO 8.1 Pulses per kWh/kvarh	–	Unsigned short	1 ... 4000	RW

Offset	Number of registers	Name	Unit	Format	Value range	Access
51762	1	DO 8.1 Pulse length	–	Unsigned short	30 ... 500	RW
51763	1	DO 8.1 Timeout	–	Unsigned short	0.1 ... 18000 Digital output remote timeout 1 ... 18000 s, 0 = Disables timeout (default)	RW
51764	1	DO 8.1 Pulse divider	–	Unsigned short	0 ... 3 0 = 1 kWh 1 = 10 kWh 2 = 100 kWh 3 = 1000 kWh	RW

A.1.8 Modbus communication parameters with the function codes 0x03, 0x04 and 0x10

Addressing the communication parameters

Table A- 11 Addressing the communication parameters

Offset	Number of registers	Name	Format	Value range	Access
62983	2	Aggregation file 1 (period length)	Unsigned long	> 3 s	RW
62985	2	Aggregation file 1 (method)	Unsigned long	0 = AUTO 1 = RMS 2 = ARITHMETIC	RW
62987	2	Aggregation file 2 (period length)	Unsigned long	Preferred integer multiplier of stage (-1) period length Integer divider of a minute, or an hour or a day	RW
62989	2	Aggregation file 2 (method)	Unsigned long	0 = AUTO 1 = RMS 2 = ARITHMETIC	RW
62991	2	DHCP ON/OFF ²⁾	Unsigned long	0 ... 1	RW
62993	2	SNTP server IP address ²⁾	Unsigned long	0 ... 0xFFFFFFFF	RW
62995	2	SNTP mode ²⁾	Unsigned long	0 = SNTP client OFF 1 = SNTP active client 2 = SNTP broadcast client	RW
62999	2	IP port number ²⁾	Unsigned long	1 ... 0xFFFF	RW
63001	2	IP address ²⁾	Unsigned long	0 ... FFFFFFFFh	RW
63003	2	Subnet ²⁾	Unsigned long	0 ... FFFFFFFFh	RW
63005	2	Gateway	Unsigned long	0 ... FFFFFFFFh	RW
63019	2	Modbus address ¹⁾	Unsigned long	1 ... 247	RW
63021	2	Baud rate ¹⁾	Unsigned long	0 = 4800 baud 1 = 9600 baud 2 = 19200 baud 3 = 38400 baud 4 = 57600 baud 5 = 115200 baud	RW

Offset	Number of registers	Name	Format	Value range	Access
63023	2	Data bits Parity bits Stop bits ¹⁾	Unsigned long	0 = 8N2 1 = 8E1 2 = 8O1 3 = 8N1	RW
63025	2	Response time ¹⁾	Unsigned long	0 ... 255	RW

1) Applies only to the PAC RS485 expansion module

2) Applies only to the PAC3220

Addressing the settings for the I&M data

Table A- 12 Addressing the settings for the I&M data

Offset	Number of registers	Name	Format	Applicable Modbus function codes	Access
64001	27	I&M 0 data	stIM0	<ul style="list-style-type: none"> • 0x03 • 0x04 	R(W)
64028	89	I&M 1 data ... I&M 4 data	stIM14	<ul style="list-style-type: none"> • 0x03 • 0x04 • 0x10 	RW
64117	27	I&M data module interface 1 ¹⁾	stIM0	<ul style="list-style-type: none"> • 0x03 • 0x04 	R(W)
64144	27	I&M data module interface 2 ¹⁾	stIM0	<ul style="list-style-type: none"> • 0x03 • 0x04 	R(W)

1) Applies only to PAC3220

A.1.9 Modbus command parameters

Addressing the command parameters

You can use Modbus function code 0x06 on the command parameters.

Table A- 13 Command parameters

Offset	Number of registers	Name	Unit	Format	Value range	Access																						
60000	1	Reset the device to the factory settings	-	Unsigned short	-	W																						
60001	1	Device reset (without changing the Modbus address)	-	Unsigned short	-	W																						
60002	1	Reset maximum values	-	Unsigned short	0	W																						
60003	1	Reset minimum values	-	Unsigned short	0	W																						
60004	1	Reset energy counters	-	Unsigned short	<table border="1"> <tr> <td>0 =</td> <td>all</td> </tr> <tr> <td>1 =</td> <td>Active energy import tariff 1</td> </tr> <tr> <td>2 =</td> <td>Active energy import tariff 2</td> </tr> <tr> <td>3 =</td> <td>Active energy export tariff 1</td> </tr> <tr> <td>4 =</td> <td>Active energy export tariff 2</td> </tr> <tr> <td>5 =</td> <td>Reactive energy import tariff 1</td> </tr> <tr> <td>6 =</td> <td>Reactive energy import tariff 2</td> </tr> <tr> <td>7 =</td> <td>Reactive energy export tariff 1</td> </tr> <tr> <td>8 =</td> <td>Reactive energy export tariff 2</td> </tr> <tr> <td>9 =</td> <td>Apparent energy tariff 1</td> </tr> <tr> <td>10 =</td> <td>Apparent energy tariff 2</td> </tr> </table>	0 =	all	1 =	Active energy import tariff 1	2 =	Active energy import tariff 2	3 =	Active energy export tariff 1	4 =	Active energy export tariff 2	5 =	Reactive energy import tariff 1	6 =	Reactive energy import tariff 2	7 =	Reactive energy export tariff 1	8 =	Reactive energy export tariff 2	9 =	Apparent energy tariff 1	10 =	Apparent energy tariff 2	W
0 =	all																											
1 =	Active energy import tariff 1																											
2 =	Active energy import tariff 2																											
3 =	Active energy export tariff 1																											
4 =	Active energy export tariff 2																											
5 =	Reactive energy import tariff 1																											
6 =	Reactive energy import tariff 2																											
7 =	Reactive energy export tariff 1																											
8 =	Reactive energy export tariff 2																											
9 =	Apparent energy tariff 1																											
10 =	Apparent energy tariff 2																											
60005	1	Synchronization of the demand period	min	Unsigned short	1 ... 60	W																						
60006	1	Tariff switchover	-	Unsigned short	0 = On-peak 1 = Off-peak	W																						
60007	1	Acknowledge the diagnostics bits ¹⁾ (cf. stored bits in unsigned long beginning offset 205)	-	Unsigned short	0 ... ffffh	W																						
60008	1	Switch outputs (if parameterized)	-	Unsigned short	<table border="1"> <tr> <td>Offh ... 1ffh</td> <td></td> </tr> <tr> <td>Byte0 0 =</td> <td>Output 0.0</td> </tr> </table>	Offh ... 1ffh		Byte0 0 =	Output 0.0	W																		
Offh ... 1ffh																												
Byte0 0 =	Output 0.0																											

Offset	Number of registers	Name	Unit	Format	Value range	Access
					Byte0 1 = Output 0.1 Byte0 64 = Output 4. Byte0 65 = Output 4.1 Byte0 128 = Output 8.0 Byte0 129 = Output 8.1 Byte1 0 = off Byte1 1 = on	
60009	1	Switching command for vector group	–	Unsigned short	High 0 ... 99, Low 0 ... 1 High byte group assignment Low byte 1 = ON, 0 = OFF	W

1) The Modbus master must acknowledge these diagnostics bits.

A.1.10 MODBUS standard device identification with the function code 0x2B

Addressing the Modbus standard device identification

You can use Modbus function code 0x2B on these device identification parameters.

Table A- 14 Modbus standard device identification parameters

Object ID	Name	Format	Access
OID 0	Manufacturer	String	R
OID 1	Manufacturer device name	String	R
OID 2	FW version/bootloader version	String	R

A.1.11 Demand value measured variables with Modbus function code 0x14

The measured variables listed below can be read out via Modbus function code 0x14 "Read File Record" in two stages.

- Stage 1 (File Number 1), preset to 10 s
- Stage 2 (File Number 2), preset to 15 min

File (FC0x14)	Offset Address	Address FC 0x03 FC 0x04	Length	Name	Format	Access
1	1	30001	2	Time stamp aggregation stage n	UNIX_TS	R
1	3	30003	2	Flags aggregation stage n	Uint32	R
1	5	30005	2	V_L1	Float	R
1	7	30007	2	V_L2	Float	R
1	9	30009	2	V_L3	Float	R
1	11	30011	2	V_L12	Float	R
1	13	30013	2	V_L23	Float	R
1	15	30015	2	V_L31	Float	R
1	17	30017	2	I_L1	Float	R
1	19	30019	2	I_L2	Float	R
1	21	30021	2	I_L3	Float	R
1	23	30023	2	VA_L1	Float	R
1	25	30025	2	VA_L2	Float	R
1	27	30027	2	VA_L3	Float	R
1	29	30029	2	P_L1	Float	R
1	31	30031	2	P_L2	Float	R
1	33	30033	2	P_L3	Float	R
1	35	30035	2	VARQ1_L1	Float	R
1	37	30037	2	VARQ1_L2	Float	R
1	39	30039	2	VARQ1_L3	Float	R
1	41	30041	2	PF_L1	Float	R
1	43	30043	2	PF_L2	Float	R
1	45	30045	2	PF_L3	Float	R
1	47	30047	2	THDV_L1	Float	R
1	49	30049	2	THDV_L2	Float	R
1	51	30051	2	THDV_L3	Float	R
1	53	30053	2	THDI_L1	Float	R
1	55	30055	2	THDI_L2	Float	R
1	57	30057	2	THDI_L3	Float	R
1	59	30059	2	FREQ	Float	R
1	61	30061	2	V_LN_AVG	Float	R
1	63	30063	2	V_LL_AVG	Float	R
1	65	30065	2	I_AVG	Float	R

File (FC0x14)	Offset Address	Address FC 0x03 FC 0x04	Length	Name	Format	Access
1	67	30067	2	VA_SUM	Float	R
1	69	30069	2	P_SUM	Float	R
1	71	30071	2	VARQ1_SUM	Float	R
1	73	30073	2	PF_SUM	Float	R
1	75	30075	2	V_BAL	Float	R
1	77	30077	2	I_BAL	Float	R
1	79	30079	2	I_N	Float	R
1	257	30257	2	Time stamp aggregation stage n	UNIX_TS	R
1	259	30259	2	Flags aggregation stage n	Uint32	R
1	261	30261	2	max_V_L1	Float	R
1	263	30263	2	max_V_L2	Float	R
1	265	30265	2	max_V_L3	Float	R
1	267	30267	2	max_V_L12	Float	R
1	269	30269	2	max_V_L23	Float	R
1	271	30271	2	max_V_L31	Float	R
1	273	30273	2	max_I_L1	Float	R
1	275	30275	2	max_I_L2	Float	R
1	277	30277	2	max_I_L3	Float	R
1	279	30279	2	max_VA_L1	Float	R
1	281	30281	2	max_VA_L2	Float	R
1	283	30283	2	max_VA_L3	Float	R
1	285	30285	2	max_P_L1	Float	R
1	287	30287	2	max_P_L2	Float	R
1	289	30289	2	max_P_L3	Float	R
1	291	30291	2	max_VARQ1_L1	Float	R
1	293	30293	2	max_VARQ1_L2	Float	R
1	295	30295	2	max_VARQ1_L3	Float	R
1	297	30297	2	max_PF_L1	Float	R
1	299	30299	2	max_PF_L2	Float	R
1	301	30301	2	max_PF_L3	Float	R
1	303	30303	2	max_THDV_L1	Float	R
1	305	30305	2	max_THDV_L2	Float	R
1	307	30307	2	max_THDV_L3	Float	R
1	309	30309	2	max_THDI_L1	Float	R
1	311	30311	2	max_THDI_L2	Float	R
1	313	30313	2	max_THDI_L3	Float	R
1	315	30315	2	max_FREQ	Float	R
1	317	30317	2	max_V_LN_AVG	Float	R
1	319	30319	2	max_V_LL_AVG	Float	R
1	321	30321	2	max_I_AVG	Float	R

File (FC0x14)	Offset Address	Address FC 0x03 FC 0x04	Length	Name	Format	Access
1	323	30323	2	max_VA_SUM	Float	R
1	325	30325	2	max_P_SUM	Float	R
1	327	30327	2	max_VARQ1_SUM	Float	R
1	329	30329	2	max_PF_SUM	Float	R
1	331	30331	2	max_V_BAL	Float	R
1	333	30333	2	max_I_BAL	Float	R
1	335	30335	2	max_I_N	Float	R
1	513	30513	2	Time stamp aggregation stage n	UNIX_TS	R
1	515	30515	2	Flags aggregation stage n	Uint32	R
1	517	30517	2	min_V_L1	Float	R
1	519	30519	2	min_V_L2	Float	R
1	521	30521	2	min_V_L3	Float	R
1	523	30523	2	min_V_L12	Float	R
1	525	30525	2	min_V_L23	Float	R
1	527	30527	2	min_V_L31	Float	R
1	529	30529	2	min_I_L1	Float	R
1	531	30531	2	min_I_L2	Float	R
1	533	30533	2	min_I_L3	Float	R
1	535	30535	2	min_VA_L1	Float	R
1	537	30537	2	min_VA_L2	Float	R
1	539	30539	2	min_VA_L3	Float	R
1	541	30541	2	min_P_L1	Float	R
1	543	30543	2	min_P_L2	Float	R
1	545	30545	2	min_P_L3	Float	R
1	547	30547	2	min_VARQ1_L1	Float	R
1	549	30549	2	min_VARQ1_L2	Float	R
1	551	30551	2	min_VARQ1_L3	Float	R
1	553	30553	2	min_PF_L1	Float	R
1	555	30555	2	min_PF_L2	Float	R
1	557	30557	2	min_PF_L3	Float	R
1	559	30559	2	min_THDV_L1	Float	R
1	561	30561	2	min_THDV_L2	Float	R
1	563	30563	2	min_THDV_L3	Float	R
1	565	30565	2	min_THDI_L1	Float	R
1	567	30567	2	min_THDI_L2	Float	R
1	569	30569	2	min_THDI_L3	Float	R
1	571	30571	2	min_FREQ	Float	R
1	573	30573	2	min_V_LN_AVG	Float	R
1	575	30575	2	min_V_LL_AVG	Float	R
1	577	30577	2	min_I_AVG	Float	R

File (FC0x14)	Offset Address	Address FC 0x03 FC 0x04	Length	Name	Format	Access
1	579	30579	2	min_VA_SUM	Float	R
1	581	30581	2	min_P_SUM	Float	R
1	583	30583	2	min_VARQ1_SUM	Float	R
1	585	30585	2	min_PF_SUM	Float	R
1	587	30587	2	min_V_BAL	Float	R
1	589	30589	2	min_I_BAL	Float	R
1	591	30591	2	min_I_N	Float	R
2	1	31001	2	Time stamp aggregation stage n	UNIX_TS	R
2	3	31003	2	Flags aggregation stage n	Uint32	R
2	5	31005	2	V_L1	Float	R
2	7	31007	2	V_L2	Float	R
2	9	31009	2	V_L3	Float	R
2	11	31011	2	V_L12	Float	R
2	13	31013	2	V_L23	Float	R
2	15	31015	2	V_L31	Float	R
2	17	31017	2	I_L1	Float	R
2	19	31019	2	I_L2	Float	R
2	21	31021	2	I_L3	Float	R
2	23	31023	2	VA_L1	Float	R
2	25	31025	2	VA_L2	Float	R
2	27	31027	2	VA_L3	Float	R
2	29	31029	2	P_L1	Float	R
2	31	31031	2	P_L2	Float	R
2	33	31033	2	P_L3	Float	R
2	35	31035	2	VARQ1_L1	Float	R
2	37	31037	2	VARQ1_L2	Float	R
2	39	31039	2	VARQ1_L3	Float	R
2	41	31041	2	PF_L1	Float	R
2	43	31043	2	PF_L2	Float	R
2	45	31045	2	PF_L3	Float	R
2	47	31047	2	THDV_L1	Float	R
2	49	31049	2	THDV_L2	Float	R
2	51	31051	2	THDV_L3	Float	R
2	53	31053	2	THDI_L1	Float	R
2	55	31055	2	THDI_L2	Float	R
2	57	31057	2	THDI_L3	Float	R
2	59	31059	2	FREQ	Float	R
2	61	31061	2	V_LN_AVG	Float	R
2	63	31063	2	V_LL_AVG	Float	R
2	65	31065	2	I_AVG	Float	R

File (FC0x14)	Offset Address	Address FC 0x03 FC 0x04	Length	Name	Format	Access
2	67	31067	2	VA_SUM	Float	R
2	69	31069	2	P_SUM	Float	R
2	71	31071	2	VARQ1_SUM	Float	R
2	73	31073	2	PF_SUM	Float	R
2	75	31075	2	V_BAL	Float	R
2	77	31077	2	I_BAL	Float	R
2	79	31079	2	I_N	Float	R
2	257	31257	2	Time stamp aggregation stage n	UNIX_TS	R
2	259	31259	2	Flags aggregation stage n	Uint32	R
2	261	31261	2	max_V_L1	Float	R
2	263	31263	2	max_V_L2	Float	R
2	265	31265	2	max_V_L3	Float	R
2	267	31267	2	max_V_L12	Float	R
2	269	31269	2	max_V_L23	Float	R
2	271	31271	2	max_V_L31	Float	R
2	273	31273	2	max_I_L1	Float	R
2	275	31275	2	max_I_L2	Float	R
2	277	31277	2	max_I_L3	Float	R
2	279	31279	2	max_VA_L1	Float	R
2	281	31281	2	max_VA_L2	Float	R
2	283	31283	2	max_VA_L3	Float	R
2	285	31285	2	max_P_L1	Float	R
2	287	31287	2	max_P_L2	Float	R
2	289	31289	2	max_P_L3	Float	R
2	291	31291	2	max_VARQ1_L1	Float	R
2	293	31293	2	max_VARQ1_L2	Float	R
2	295	31295	2	max_VARQ1_L3	Float	R
2	297	31297	2	max_PF_L1	Float	R
2	299	31299	2	max_PF_L2	Float	R
2	301	31301	2	max_PF_L3	Float	R
2	303	31303	2	max_THDV_L1	Float	R
2	305	31305	2	max_THDV_L2	Float	R
2	307	31307	2	max_THDV_L3	Float	R
2	309	31309	2	max_THDI_L1	Float	R
2	311	31311	2	max_THDI_L2	Float	R
2	313	31313	2	max_THDI_L3	Float	R
2	315	31315	2	max_FREQ	Float	R
2	317	31317	2	max_V_LN_AVG	Float	R
2	319	31319	2	max_V_LL_AVG	Float	R
2	321	31321	2	max_I_AVG	Float	R

File (FC0x14)	Offset Address	Address FC 0x03 FC 0x04	Length	Name	Format	Access
2	323	31323	2	max_VA_SUM	Float	R
2	325	31325	2	max_P_SUM	Float	R
2	327	31327	2	max_VARQ1_SUM	Float	R
2	329	31329	2	max_PF_SUM	Float	R
2	331	31331	2	max_V_BAL	Float	R
2	333	31333	2	max_I_BAL	Float	R
2	335	31335	2	max_I_N	Float	R
2	513	31513	2	Time stamp aggregation stage n	UNIX_TS	R
2	515	31515	2	Flags aggregation stage n	Uint32	R
2	517	31517	2	min_V_L1	Float	R
2	519	31519	2	min_V_L2	Float	R
2	521	31521	2	min_V_L3	Float	R
2	523	31523	2	min_V_L12	Float	R
2	525	31525	2	min_V_L23	Float	R
2	527	31527	2	min_V_L31	Float	R
2	529	31529	2	min_I_L1	Float	R
2	531	31531	2	min_I_L2	Float	R
2	533	31533	2	min_I_L3	Float	R
2	535	31535	2	min_VA_L1	Float	R
2	537	31537	2	min_VA_L2	Float	R
2	539	31539	2	min_VA_L3	Float	R
2	541	31541	2	min_P_L1	Float	R
2	543	31543	2	min_P_L2	Float	R
2	545	31545	2	min_P_L3	Float	R
2	547	31547	2	min_VARQ1_L1	Float	R
2	549	31549	2	min_VARQ1_L2	Float	R
2	551	31551	2	min_VARQ1_L3	Float	R
2	553	31553	2	min_PF_L1	Float	R
2	555	31555	2	min_PF_L2	Float	R
2	557	31557	2	min_PF_L3	Float	R
2	559	31559	2	min_THDV_L1	Float	R
2	561	31561	2	min_THDV_L2	Float	R
2	563	31563	2	min_THDV_L3	Float	R
2	565	31565	2	min_THDI_L1	Float	R
2	567	31567	2	min_THDI_L2	Float	R
2	569	31569	2	min_THDI_L3	Float	R
2	571	31571	2	min_FREQ	Float	R
2	573	31573	2	min_V_LN_AVG	Float	R
2	575	31575	2	min_V_LL_AVG	Float	R
2	577	31577	2	min_I_AVG	Float	R

Appendix

A.1 Modbus

File (FC0x14)	Offset Address	Address FC 0x03 FC 0x04	Length	Name	Format	Access
2	579	31579	2	min_VA_SUM	Float	R
2	581	31581	2	min_P_SUM	Float	R
2	583	31583	2	min_VARQ1_SUM	Float	R
2	585	31585	2	min_PF_SUM	Float	R
2	587	31587	2	min_V_BAL	Float	R
2	589	31589	2	min_I_BAL	Float	R
2	591	31591	2	min_I_N	Float	R

A.1.12 Active energy history with Modbus function code 0x14

The active energy counters listed below can be read out via Modbus function code 0x14 "Read File Record".

- The daily energy counter (file number 90) records the active energy for each day of the preceding two months.
- The monthly energy counter (file number 91) records the active energy for each month of the preceding two years.

File (FC0x14)	Offset address	Address FC0x03 FC0x04	Length	Name	Format	Access
90	1	32001	2	Error state	Bool	R
90	3	32003	2	TS actual period	UNIX_TS (UTC)	R
90	5	32005	2	Work portion today Tariff 1	Float	R
90	7	32007	2	Work portion today Tariff 2	Float	R
90	9	32009	2	TS of day – 1	UNIX_TS (UTC)	R
90	11	32011	2	Work portion Tariff 1	Float	R
90	13	32013	2	Work portion Tariff 2	Float	R
90	15	32015	2	TS of day – 2	UNIX_TS (UTC)	R
90	17	32017	2	Work portion Tariff 1	Float	R
90	19	32019	2	Work portion Tariff 2	Float	R
90	21	32021	2	TS of day – 3	UNIX_TS (UTC)	R
90	23	32023	2	Work portion Tariff 1	Float	R
90	25	32025	2	Work portion Tariff 2	Float	R
90	27	32027	2	TS of day – 4	UNIX_TS (UTC)	R
90	29	32029	2	Work portion Tariff 1	Float	R
90	31	32031	2	Work portion Tariff 2	Float	R
90	33	32033	2	TS of day – 5	UNIX_TS (UTC)	R
90	35	32035	2	Work portion Tariff 1	Float	R
90	37	32037	2	Work portion Tariff 2	Float	R
90	39	32039	2	TS of day – 6	UNIX_TS (UTC)	R
90	41	32041	2	Work portion Tariff 1	Float	R
90	43	32043	2	Work portion Tariff 2	Float	R
90	45	32045	2	TS of day – 7	UNIX_TS (UTC)	R
90	47	32047	2	Work portion Tariff 1	Float	R
90	49	32049	2	Work portion Tariff 2	Float	R
90	51	32051	2	TS of day – 8	UNIX_TS (UTC)	R
90	53	32053	2	Work portion Tariff 1	Float	R
90	55	32055	2	Work portion Tariff 2	Float	R
90	57	32057	2	TS of day – 9	UNIX_TS (UTC)	R
90	59	32059	2	Work portion Tariff 1	Float	R
90	61	32061	2	Work portion Tariff 2	Float	R
90	63	32063	2	TS of day – 10	UNIX_TS (UTC)	R

Appendix

A.1 Modbus

File (FC0x14)	Offset address	Address FC0x03 FC0x04	Length	Name	Format	Access
90	65	32065	2	Work portion Tariff 1	Float	R
90	67	32067	2	Work portion Tariff 2	Float	R
90	69	32069	2	TS of day – 11	UNIX_TS (UTC)	R
90	71	32071	2	Work portion Tariff 1	Float	R
90	73	32073	2	Work portion Tariff 2	Float	R
90	75	32075	2	TS of day – 12	UNIX_TS (UTC)	R
90	77	32077	2	Work portion Tariff 1	Float	R
90	79	32079	2	Work portion Tariff 2	Float	R
90	81	32081	2	TS of day – 13	UNIX_TS (UTC)	R
90	83	32083	2	Work portion Tariff 1	Float	R
90	85	32085	2	Work portion Tariff 2	Float	R
90	87	32087	2	TS of day – 14	UNIX_TS (UTC)	R
90	89	32089	2	Work portion Tariff 1	Float	R
90	91	32091	2	Work portion Tariff 2	Float	R
90	93	32093	2	TS of day – 15	UNIX_TS (UTC)	R
90	95	32095	2	Work portion Tariff 1	Float	R
90	97	32097	2	Work portion Tariff 2	Float	R
90	99	32099	2	TS of day – 16	UNIX_TS (UTC)	R
90	101	32101	2	Work portion Tariff 1	Float	R
90	103	32103	2	Work portion Tariff 2	Float	R
90	105	32105	2	TS of day – 17	UNIX_TS (UTC)	R
90	107	32107	2	Work portion Tariff 1	Float	R
90	109	32109	2	Work portion Tariff 2	Float	R
90	111	32111	2	TS of day – 18	UNIX_TS (UTC)	R
90	113	32113	2	Work portion Tariff 1	Float	R
90	115	32115	2	Work portion Tariff 2	Float	R
90	117	32117	2	TS of day – 19	UNIX_TS (UTC)	R
90	119	32119	2	Work portion Tariff 1	Float	R
90	121	32121	2	Work portion Tariff 2	Float	R
90	123	32123	2	TS of day – 20	UNIX_TS (UTC)	R
90	125	32125	2	Work portion Tariff 1	Float	R
90	127	32127	2	Work portion Tariff 2	Float	R
90	129	32129	2	TS of day – 21	UNIX_TS (UTC)	R
90	131	32131	2	Work portion Tariff 1	Float	R
90	133	32133	2	Work portion Tariff 2	Float	R
90	135	32135	2	TS of day – 22	UNIX_TS (UTC)	R
90	137	32137	2	Work portion Tariff 1	Float	R
90	139	32139	2	Work portion Tariff 2	Float	R
90	141	32141	2	TS of day – 23	UNIX_TS (UTC)	R
90	143	32143	2	Work portion Tariff 1	Float	R

File (FC0x14)	Offset address	Address FC0x03 FC0x04	Length	Name	Format	Access
90	145	32145	2	Work portion Tariff 2	Float	R
90	147	32147	2	TS of day – 24	UNIX_TS (UTC)	R
90	149	32149	2	Work portion Tariff 1	Float	R
90	151	32151	2	Work portion Tariff 2	Float	R
90	153	32153	2	TS of day – 25	UNIX_TS (UTC)	R
90	155	32155	2	Work portion Tariff 1	Float	R
90	157	32157	2	Work portion Tariff 2	Float	R
90	159	32159	2	TS of day – 26	UNIX_TS (UTC)	R
90	161	32161	2	Work portion Tariff 1	Float	R
90	163	32163	2	Work portion Tariff 2	Float	R
90	165	32165	2	TS of day – 27	UNIX_TS (UTC)	R
90	167	32167	2	Work portion Tariff 1	Float	R
90	169	32169	2	Work portion Tariff 2	Float	R
90	171	32171	2	TS of day – 28	UNIX_TS (UTC)	R
90	173	32173	2	Work portion Tariff 1	Float	R
90	175	32175	2	Work portion Tariff 2	Float	R
90	177	32177	2	TS of day – 29	UNIX_TS (UTC)	R
90	179	32179	2	Work portion Tariff 1	Float	R
90	181	32181	2	Work portion Tariff 2	Float	R
90	183	32183	2	TS of day – 30	UNIX_TS (UTC)	R
90	185	32185	2	Work portion Tariff 1	Float	R
90	187	32187	2	Work portion Tariff 2	Float	R
90	189	32189	2	TS of day – 31	UNIX_TS (UTC)	R
90	191	32191	2	Work portion Tariff 1	Float	R
90	193	32193	2	Work portion Tariff 2	Float	R
90	195	32195	2	TS of day – 32	UNIX_TS (UTC)	R
90	197	32197	2	Work portion Tariff 1	Float	R
90	199	32199	2	Work portion Tariff 2	Float	R
90	201	32201	2	TS of day – 33	UNIX_TS (UTC)	R
90	203	32203	2	Work portion Tariff 1	Float	R
90	205	32205	2	Work portion Tariff 2	Float	R
90	207	32207	2	TS of day – 34	UNIX_TS (UTC)	R
90	209	32209	2	Work portion Tariff 1	Float	R
90	211	32211	2	Work portion Tariff 2	Float	R
90	213	32213	2	TS of day – 35	UNIX_TS (UTC)	R
90	215	32215	2	Work portion Tariff 1	Float	R
90	217	32217	2	Work portion Tariff 2	Float	R
90	219	32219	2	TS of day – 36	UNIX_TS (UTC)	R
90	221	32221	2	Work portion Tariff 1	Float	R
90	223	32223	2	Work portion Tariff 2	Float	R

Appendix

A.1 Modbus

File (FC0x14)	Offset address	Address FC0x03 FC0x04	Length	Name	Format	Access
90	225	32225	2	TS of day – 37	UNIX_TS (UTC)	R
90	227	32227	2	Work portion Tariff 1	Float	R
90	229	32229	2	Work portion Tariff 2	Float	R
90	231	32231	2	TS of day – 38	UNIX_TS (UTC)	R
90	233	32233	2	Work portion Tariff 1	Float	R
90	235	32235	2	Work portion Tariff 2	Float	R
90	237	32237	2	TS of day – 39	UNIX_TS (UTC)	R
90	239	32239	2	Work portion Tariff 1	Float	R
90	241	32241	2	Work portion Tariff 2	Float	R
90	243	32243	2	TS of day – 40	UNIX_TS (UTC)	R
90	245	32245	2	Work portion Tariff 1	Float	R
90	247	32247	2	Work portion Tariff 2	Float	R
90	249	32249	2	TS of day – 41	UNIX_TS (UTC)	R
90	251	32251	2	Work portion Tariff 1	Float	R
90	253	32253	2	Work portion Tariff 2	Float	R
90	255	32255	2	TS of day – 42	UNIX_TS (UTC)	R
90	257	32257	2	Work portion Tariff 1	Float	R
90	259	32259	2	Work portion Tariff 2	Float	R
90	261	32261	2	TS of day – 43	UNIX_TS (UTC)	R
90	263	32263	2	Work portion Tariff 1	Float	R
90	265	32265	2	Work portion Tariff 2	Float	R
90	267	32267	2	TS of day – 44	UNIX_TS (UTC)	R
90	269	32269	2	Work portion Tariff 1	Float	R
90	271	32271	2	Work portion Tariff 2	Float	R
90	273	32273	2	TS of day – 45	UNIX_TS (UTC)	R
90	275	32275	2	Work portion Tariff 1	Float	R
90	277	32277	2	Work portion Tariff 2	Float	R
90	279	32279	2	TS of day – 46	UNIX_TS (UTC)	R
90	281	32281	2	Work portion Tariff 1	Float	R
90	283	32283	2	Work portion Tariff 2	Float	R
90	285	32285	2	TS of day – 47	UNIX_TS (UTC)	R
90	287	32287	2	Work portion Tariff 1	Float	R
90	289	32289	2	Work portion Tariff 2	Float	R
90	291	32291	2	TS of day – 48	UNIX_TS (UTC)	R
90	293	32293	2	Work portion Tariff 1	Float	R
90	295	32295	2	Work portion Tariff 2	Float	R
90	297	32297	2	TS of day – 49	UNIX_TS (UTC)	R
90	299	32299	2	Work portion Tariff 1	Float	R
90	301	32301	2	Work portion Tariff 2	Float	R
90	303	32303	2	TS of day – 50	UNIX_TS (UTC)	R

File (FC0x14)	Offset address	Address FC0x03 FC0x04	Length	Name	Format	Access
90	305	32305	2	Work portion Tariff 1	Float	R
90	307	32307	2	Work portion Tariff 2	Float	R
90	309	32309	2	TS of day – 51	UNIX_TS (UTC)	R
90	311	32311	2	Work portion Tariff 1	Float	R
90	313	32313	2	Work portion Tariff 2	Float	R
90	315	32315	2	TS of day – 52	UNIX_TS (UTC)	R
90	317	32317	2	Work portion Tariff 1	Float	R
90	319	32319	2	Work portion Tariff 2	Float	R
90	321	32321	2	TS of day – 53	UNIX_TS (UTC)	R
90	323	32323	2	Work portion Tariff 1	Float	R
90	325	32325	2	Work portion Tariff 2	Float	R
90	327	32327	2	TS of day – 54	UNIX_TS (UTC)	R
90	329	32329	2	Work portion Tariff 1	Float	R
90	331	32331	2	Work portion Tariff 2	Float	R
90	333	32333	2	TS of day – 55	UNIX_TS (UTC)	R
90	335	32335	2	Work portion Tariff 1	Float	R
90	337	32337	2	Work portion Tariff 2	Float	R
90	339	32339	2	TS of day – 56	UNIX_TS (UTC)	R
90	341	32341	2	Work portion Tariff 1	Float	R
90	343	32343	2	Work portion Tariff 2	Float	R
90	345	32345	2	TS of day – 57	UNIX_TS (UTC)	R
90	347	32347	2	Work portion Tariff 1	Float	R
90	349	32349	2	Work portion Tariff 2	Float	R
90	351	32351	2	TS of day – 58	UNIX_TS (UTC)	R
90	353	32353	2	Work portion Tariff 1	Float	R
90	355	32355	2	Work portion Tariff 2	Float	R
90	357	32357	2	TS of day – 59	UNIX_TS (UTC)	R
90	359	32359	2	Work portion Tariff 1	Float	R
90	361	32361	2	Work portion Tariff 2	Float	R
90	363	32363	2	TS of day – 60	UNIX_TS (UTC)	R
90	365	32365	2	Work portion Tariff 1	Float	R
90	367	32367	2	Work portion Tariff 2	Float	R
90	369	32369	2	TS of day – 61	UNIX_TS (UTC)	R
90	371	32371	2	Work portion Tariff 1	Float	R
90	373	32373	2	Work portion Tariff 2	Float	R
90	375	32375	2	TS of day – 62	UNIX_TS (UTC)	R
90	377	32377	2	Work portion Tariff 1	Float	R
90	379	32379	2	Work portion Tariff 2	Float	R
90	381	32381	2	TS of day – 63	UNIX_TS (UTC)	R
90	383	32383	2	Work portion Tariff 1	Float	R

Appendix

A.1 Modbus

File (FC0x14)	Offset address	Address FC0x03 FC0x04	Length	Name	Format	Access
90	385	32385	2	Work portion Tariff 2	Float	R
90	387	32387	2	TS of day - 64	UNIX_TS (UTC)	R
90	389	32389	2	Work portion Tariff 1	Float	R
90	391	32391	2	Work portion Tariff 2	Float	R

File (FC0x14)	Offset Address	Address FC 0x03 FC 0x04	Length	Name	Format	Access
91	1	32401	2	Error state	Bool	R
91	3	32403	2	TS actual period	UNIX_TS (UTC)	R
91	5	32405	2	Work portion this month Tariff 1	Float	R
91	7	32407	2	Work portion this month Tariff 2	Float	R
91	9	32409	2	TS of month - 1	UNIX_TS (UTC)	R
91	11	32411	2	Work portion Tariff 1	Float	R
91	13	32413	2	Work portion Tariff 2	Float	R
91	15	32415	2	TS of month - 2	UNIX_TS (UTC)	R
91	17	32417	2	Work portion Tariff 1	Float	R
91	19	32419	2	Work portion Tariff 2	Float	R
91	21	32421	2	TS of month - 3	UNIX_TS (UTC)	R
91	23	32423	2	Work portion Tariff 1	Float	R
91	25	32425	2	Work portion Tariff 2	Float	R
91	27	32427	2	TS of month - 4	UNIX_TS (UTC)	R
91	29	32429	2	Work portion Tariff 1	Float	R
91	31	32431	2	Work portion Tariff 2	Float	R
91	33	32433	2	TS of month - 5	UNIX_TS (UTC)	R
91	35	32435	2	Work portion Tariff 1	Float	R
91	37	32437	2	Work portion Tariff 2	Float	R
91	39	32439	2	TS of month - 6	UNIX_TS (UTC)	R
91	41	32441	2	Work portion Tariff 1	Float	R
91	43	32443	2	Work portion Tariff 2	Float	R
91	45	32445	2	TS of month - 7	UNIX_TS (UTC)	R
91	47	32447	2	Work portion Tariff 1	Float	R
91	49	32449	2	Work portion Tariff 2	Float	R
91	51	32451	2	TS of month - 8	UNIX_TS (UTC)	R
91	53	32453	2	Work portion Tariff 1	Float	R
91	55	32455	2	Work portion Tariff 2	Float	R
91	57	32457	2	TS of month - 9	UNIX_TS (UTC)	R
91	59	32459	2	Work portion Tariff 1	Float	R
91	61	32461	2	Work portion Tariff 2	Float	R

File (FC0x14)	Offset Address	Address FC 0x03 FC 0x04	Length	Name	Format	Access
91	63	32463	2	TS of month – 10	UNIX_TS (UTC)	R
91	65	32465	2	Work portion Tariff 1	Float	R
91	67	32467	2	Work portion Tariff 2	Float	R
91	69	32469	2	TS of month – 11	UNIX_TS (UTC)	R
91	71	32471	2	Work portion Tariff 1	Float	R
91	73	32473	2	Work portion Tariff 2	Float	R
91	75	32475	2	TS of month – 12	UNIX_TS (UTC)	R
91	77	32477	2	Work portion Tariff 1	Float	R
91	79	32479	2	Work portion Tariff 2	Float	R
91	81	32481	2	TS of month – 13	UNIX_TS (UTC)	R
91	83	32483	2	Work portion Tariff 1	Float	R
91	85	32485	2	Work portion Tariff 2	Float	R
91	87	32487	2	TS of month – 14	UNIX_TS (UTC)	R
91	89	32489	2	Work portion Tariff 1	Float	R
91	91	32491	2	Work portion Tariff 2	Float	R
91	93	32493	2	TS of month – 15	UNIX_TS (UTC)	R
91	95	32495	2	Work portion Tariff 1	Float	R
91	97	32497	2	Work portion Tariff 2	Float	R
91	99	32499	2	TS of month – 16	UNIX_TS (UTC)	R
91	101	32501	2	Work portion Tariff 1	Float	R
91	103	32503	2	Work portion Tariff 2	Float	R
91	105	32505	2	TS of month – 17	UNIX_TS (UTC)	R
91	107	32507	2	Work portion Tariff 1	Float	R
91	109	32509	2	Work portion Tariff 2	Float	R
91	111	32511	2	TS of month – 18	UNIX_TS (UTC)	R
91	113	32513	2	Work portion Tariff 1	Float	R
91	115	32515	2	Work portion Tariff 2	Float	R
91	117	32517	2	TS of month – 19	UNIX_TS (UTC)	R
91	119	32519	2	Work portion Tariff 1	Float	R
91	121	32521	2	Work portion Tariff 2	Float	R
91	123	32523	2	TS of month – 20	UNIX_TS (UTC)	R
91	125	32525	2	Work portion Tariff 1	Float	R
91	127	32527	2	Work portion Tariff 2	Float	R
91	129	32529	2	TS of month – 21	UNIX_TS (UTC)	R
91	131	32531	2	Work portion Tariff 1	Float	R
91	133	32533	2	Work portion Tariff 2	Float	R
91	135	32535	2	TS of month – 22	UNIX_TS (UTC)	R
91	137	32537	2	Work portion Tariff 1	Float	R
91	139	32539	2	Work portion Tariff 2	Float	R
91	141	32541	2	TS of month – 23	UNIX_TS (UTC)	R

Appendix

A.1 Modbus

File (FC0x14)	Offset Address	Address FC 0x03 FC 0x04	Length	Name	Format	Access
91	143	32543	2	Work portion Tariff 1	Float	R
91	145	32545	2	Work portion Tariff 2	Float	R
91	147	32547	2	TS of month - 24	UNIX_TS (UTC)	R
91	149	32549	2	Work portion Tariff 1	Float	R
91	151	32551	2	Work portion Tariff 2	Float	R

Index

A

Ambient conditions, 104

B

Bit mask, 120

C

Cleaning, 93
Clearance measurements, 110
Command parameters, 138
Communication, 29, 53, 99, 99
Communication parameters, 136
Connection
 RS485 interface, 53
Connection components, 101
Connection designations, 42
Connection type
 Checking, 60
 Dependency of the measured variables, 18
Connection types, 17
Counters, 14, 22

D

Degree of protection, 103
Deinstallation, 38
Device diagnostics, 120
Device identification parameters, 139
Device status, 120
Digital output, 27
Dimensions, 109
 Clearance measurements, 110
 Frame dimensions, 109
 Panel cutout, 109
Direction of current flow, 59
Display
 Measured variables depending on the connection type, 18

E

Energy counters, 22

Error code, 113
Ethernet interface, 99
Exception code, 112

F

Frame dimensions, 109
Function code, 111, 139

G

General safety notes, 10

I

Installation space
 Ventilation, 36
Installation tools, 37

M

Measured value acquisition, 95
Measured variables
 Display, 18
Measuring method, 95
Modbus
 Exception codes, 112
Modbus function code, 113, 121, 123, 138, 139
Modbus measured variables, 113
Modbus RTU, 29, 53, 99, 99
Mounting
 Procedure, 37
Mounting dimensions, 109
Mounting location, 35
Mounting position, 35

O

Object ID, 139
Offset, 112, 120, 121, 138
Open Source Software, 8
 Use, 9

P

- Panel cutout
 - Dimensions, 109
- Parameter
 - Status, 121
- Parameter assignment
 - Device settings, 69
- Parameters
 - Command, 138
 - Communication, 136
 - Device information, 139
- Power demand, 14, 22
- Prerequisites
 - Startup, 55
- Procedure
 - Mounting, 37
- Protection class, 103

R

- Register, 112, 121, 138
- Repair, 94
 - Loss of warranty, 94
- RS485 interface, 29, 53, 99

S

- Scope of supply, 7
- Screw terminal, 101
- Security functions, 9
- Startup, 55
 - Prerequisites, 55
- Status parameters, 121

T

- Technical data, 95
 - Ambient conditions, 104
 - Communication, 99, 99
 - Connection components, 101
 - Degree of protection, 103
 - Digital inputs, 98
 - Digital outputs, 98
 - Display, 100, 100
 - Measuring accuracy, 97
 - Measuring inputs, 96, 96
 - Measuring inputs current, 96
 - Measuring inputs voltage, 96
 - Protection class, 103
 - RS485 interface, 99, 99

- Screw terminal, 101
- Supply voltage, 97
- Technical Support, 8
- Turn-off time, 28

V

- Ventilation
 - Installation space, 36

Further information

Always at your service: our comprehensive support
www.siemens.com/online-support

Siemens AG
Smart Infrastructure
Low Voltage Products
Postfach 10 09 53
93009 REGENSBURG
Germany

Subject to change without prior
notice.
3ZW1012-0KM31-0AB1
© Siemens AG 2019

SI LP
Online

